

Eaton UltraShift® PLUS TRIG1110 EN-US

July 2015

UltraShift® PLUS Linehaul Active Shifting (LAS)
UltraShift® PLUS Linehaul Small Step Efficiency (LSE)
UltraShift® PLUS Multipurpose Extreme Performance (MXP)
UltraShift® PLUS Multipurpose High Performance (MHP)
UltraShift® PLUS Vocational Active Shifting (VAS)
UltraShift® PLUS Vocational Construction Series (VCS)
UltraShift® PLUS Vocational High Performance (VHP)
UltraShift® PLUS Vocational Multipurpose Series (VMS)
UltraShift® PLUS Vocational Extreme Performance (VXP)



Powering Business Worldwide

BACKED BY
Roadranger
SUPPORT

Introduction and General Information

Warnings and Cautions

This symbol is used throughout this manual to call attention to procedures where carelessness or failure to follow specific instructions may result in personal injury and/or component damage.

Departure from the instructions, choice of tools, materials and recommended parts mentioned in this publication may jeopardize the personal safety of the service technician or vehicle operator.



Warning: Failure to follow indicated procedures creates a high risk of personal injury to the servicing technician.

Caution: Failure to follow indicated procedures may cause component damage or malfunction.

Important: Highly recommended procedures for proper service of this unit.

Note: Additional service information not covered in the service procedures.

Tip: Helpful removal and installation procedures to aid in the service of this unit.

Important Notice

Any reference to brand name in this publication is made as an example of the types of tools and materials recommended for use and should not be considered an endorsement. Equivalents may be used.

The description and specifications contained in this service publication are current at the time of printing.

Eaton Corporation reserves the right to discontinue or modify its models and/or procedures and to change specifications at any time without notice.

Table of Contents

Section 1: Introduction / General Information

About this Manual	1
Product Familiarization	5
Suggested Tools/Publications	7
Vendor List	8

Section 2: Vehicle Space Claim

Vehicle Space Claim	9
Shift Label Requirements	10
Eaton Shift Console Space Requirements	11
Eaton Shift Lever and Tower Space Requirements	12
Vehicle Space Claim	13

Section 3: Clutch Interface

Clutch Interface	19
ECA Clutch Installation	20

Section 4: Transmission Interface

Transmission Interface	22
Air Supply and Air Drying Requirements	24
Lubrication Requirements and Specifications	25
Cooler Requirements	28

Section 5: Electrical System Interface

Electrical Wiring Requirements	30
Electrical Wiring Recommendations	35
Power Harness	38
Ignition Circuit Detail	42
Typical Start Enable Relay Circuit	43
Typical System with Eaton Push Button	44
Typical System with Eaton Shift Lever	47
Dimmer Control Input Connection	48
Diagnostic Connector	49
J1939/15 Data Link	50
SAE J1939 Data Link Broadcast Messages	52
SAE J1939 Data Link Received Messages	57
SAE J1587 Data Link Broadcast Messages	63

Section 6: System Integration Specifications

Gear Display	64
--------------------	----

Section 7: Auxiliary Equipment Interface

PTO Inputs and Configurations 71
 Transmission Mounted PTO Inputs 71
 Transmission Mounted and Split Shaft PTO Configurations 72
 Split Shaft Power Take Off (SSPTO)..... 73
 PTO Wiring Diagrams 76

Section 8: Line Inspection and End of Line

Line Inspection and Road Test Instructions 78
 Line Inspection Form - Fuller UltraShift PLUS models 83
 Line Inspection Form OEM Wiring Connector/Harness 84

Section 9: Appendix

Wiring Diagram - OEM Responsibility 95
 UltraShift PLUS LAS, LSE, MXP, MHP, VAS, VCS, VHP, VMS and VXP
 Wiring Diagram with Analog Shifter 97
 UltraShift PLUS LAS, LSE, MXP, MHP, VAS, VCS, VHP, VMS and VXP
 Wiring Diagram with Push Button Shifter 99
 Connector Pin Descriptions 101
 Torque Specifications 103
 Change Control Log 106

About this Manual

This installation guide references design employing the Generation 2 ECA Power Pack being supplied after November 1 2015. ECA motors used prior to that date will not have electrical connection information available in this guide.

This Eaton® publication is intended to be a reference guide for the installation of the Fuller® UltraShift® PLUS LAS, LSE, MXP, MHP, VAS, VCS, VHP, VMS and VXP transmissions. General vehicle and transmission information is provided to cover the wide range of applications. This information benefits the OEM installer by providing the correct installation procedures to ensure the utmost in satisfactory operation and long service life. For additional transmission information, see the Suggested Tools section in this manual. For specific engine information contact the engine OEM.

Failure to adhere to Eaton Installation Requirements may affect transmission performance and/or warranty coverage.

Fuller UltraShift PLUS models LAS, LSE, MXP, MHP, VAS, VCS, VHP, VMS and VXP are compatible with electronically governed engines equipped with a J1939 data link and certified by Eaton Corporation. Transmissions installed at OEM facilities shall meet and be approved by Eaton Application Engineering. Contact Eaton Application Engineering or your OEM Application Engineering department for the proper Application form. All applications shall be submitted for approval.

OEM Design Responsibility

OEM facilities shall submit a design package to Eaton Corporation OEM Engineering Support Group for approval prior to any OEM build. A design package consists of the following information.

Transmission air supply: Source of air supply and routing and clipping of air supply line.

Transmission cooling system: Cooler type and capacity, cooler hose(s) routing and clipping.

Battery power and ground: Detailed drawing of battery power and ground scheme.

Individual harness drawings: Construction detail of individual wiring harnesses including harness routing location and clipping points.

Wiring schematic: High-level schematic of how this transmission interfaces with the vehicle.

Application Approval

Fuller UltraShift PLUS LAS, LSE, MXP, MHP, VAS, VCS, VHP, VMS and VXP model transmission systems installed at OEM facilities must meet the requirements and be approved using the Eaton Transmission Application Approval Form. Please contact Eaton Application Engineering or your OEM's Application department for the latest Application form.

- **Driveline Torque Requirements** - Driveline angular acceleration and driveline torque shall not exceed requirements stated in Eaton Application Guideline specification TRAG2600.
- **Applications and PTO Applications**- refer to Application Guidelines Manual TRAG2600 and PTO Torque Limits TMIB0127 for PTO application guidelines.

Every effort has been made to ensure the accuracy of the information contained in this manual. However, Eaton Corporation makes no warranty, either expressed or implied, based on the information provided. With each new application, engine manufacturers should be contacted to make sure desired engines are compatible with these systems.

Transmission Identification Tag

All UltraShift transmissions are supplied with component identification tags. All tags are located on the bottom, right rear corner of the transmission.

Care should be taken not to damage the identification tag during the installation process.

Do not remove the identification tag.

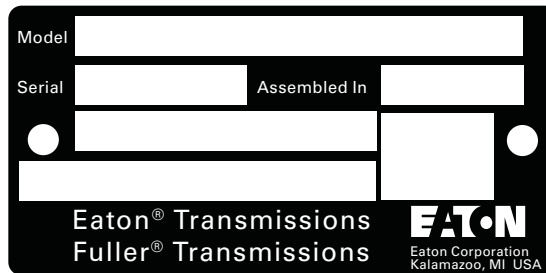

Product Identification

Nomenclature

Fuller® UltraShift® PLUS Performance Transmissions

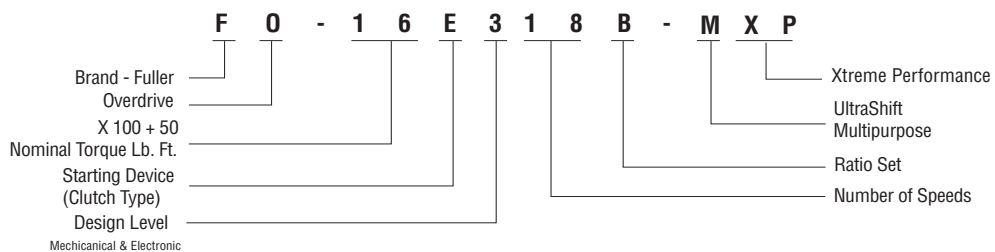
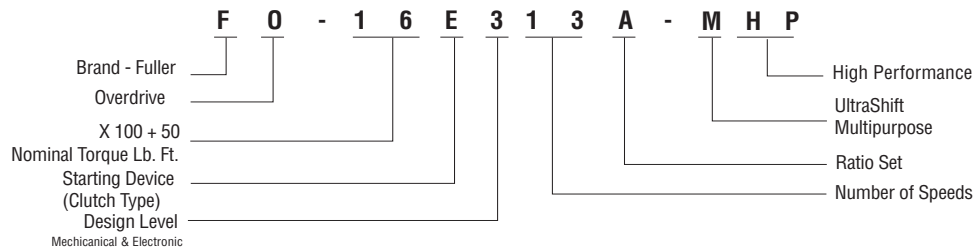

General Information

Fuller® UltraShift® PLUS Vocational Transmissions

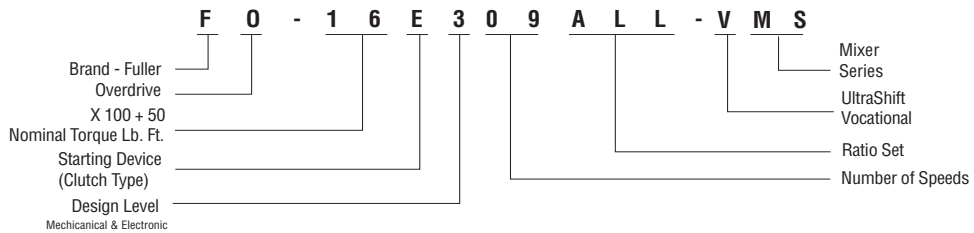
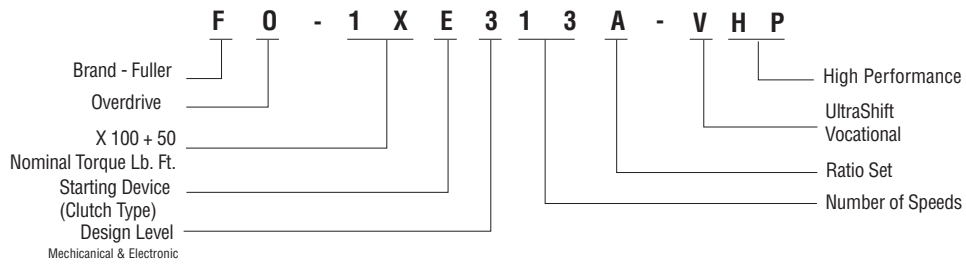
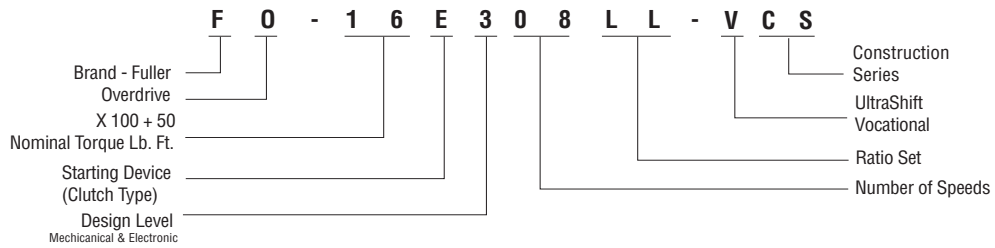
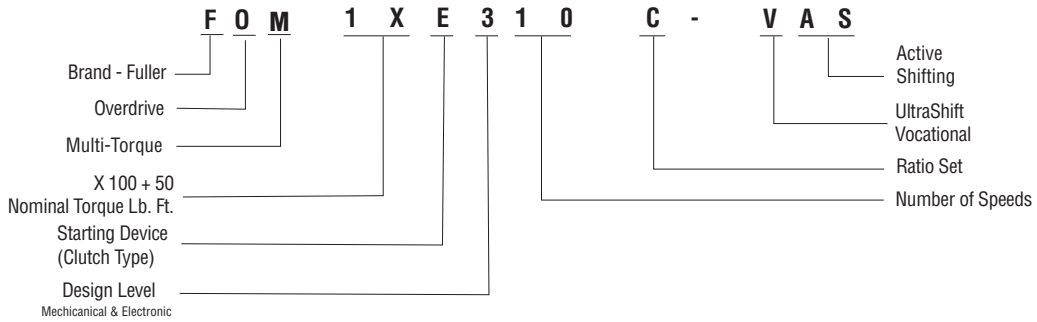
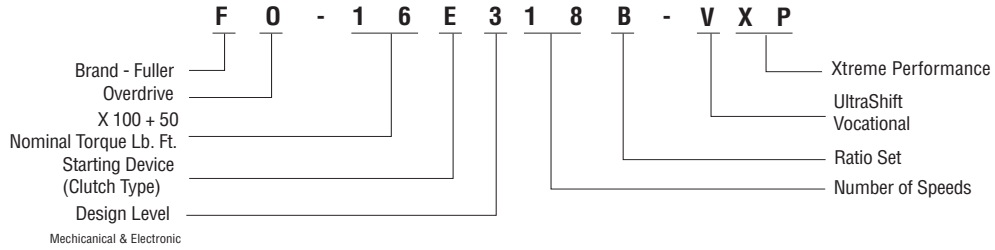

Fuller® UltraShift® PLUS Linehaul Transmissions

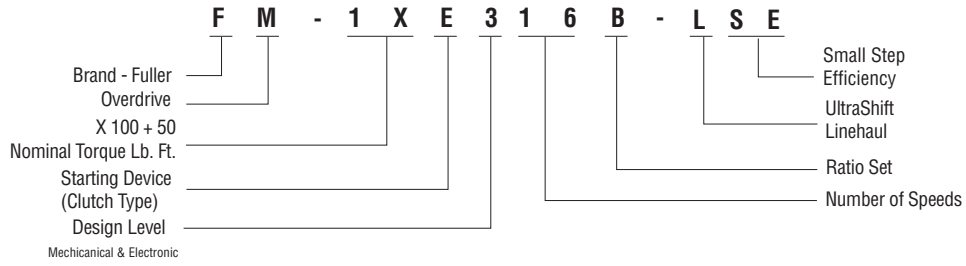
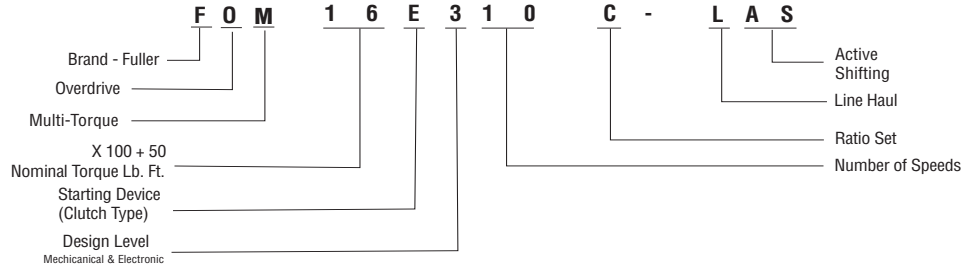

Product Familiarization

Similarities and Differences Compared to Current Automated Products

Note: In all cases where differences have been identified, see the respective installation requirements for details.

Similarities with Fuller[®] UltraShift[®] *PLUS* Products compared to AutoShift[®] and UltraShift[®] Products

- Identical PTO locations and PTO fit up requirements.
- Identical shift device options.
- Utilizes Gen 3 ECU and electrical connections
- Includes advanced Gen 3 diagnostic capabilities.
- Identical neutral and reverse switch option and locations.
- Identical transmission oil filter option locations.

Differences and Features with Fuller UltraShift *PLUS* Products

- Additional 47 mm length added to transmission due to new ECA clutch housing.
- A MEHR circuit is not required for the Fuller UltraShift *PLUS* transmissions.
- New 12/24 Volt capable Electric Clutch Actuator (ECA) to manage clutch engagement for improved transmission shifting. This requires the OEM to connect a power harness and ground.
- New ECA Clutch which is automatically adjusted at the OEM prior to vehicle being driven.
- This new design requires the OEM to install the grease hose with push to connect fittings that are pre installed.
- Zerk fittings for cross shaft and release bearing are co-located and easily accessible on the outside of the clutch housing for servicing. Both the cross shaft and release bearing are pre-lubed by Eaton. However, the OEM is required to purge the air from the release bearing zerk fitting and hose.
- A new latched Clutch access cover for ease of removal and installation.
- A Hill Start Aid system is required with this transmission. The OEM is required to install an operator accessible On/Off override control switch with warning lamp to communicate status system messages, additional brake valves and specific ABS controllers.
- A minimum of 4 Channel (4S/4M) Traction control (ATC) system compatible with UltraShift *PLUS* Hill Start Aid (HSA) is required. Other traction control configurations greater than 4S/4M are approved.
- HSA & ATC compatible with UltraShift *PLUS* are required on export vehicles where ABS is mandated by local law and optional on vehicle configurations where ABS is not mandated by local law.
- A new 2 bolt end yoke retaining design has been implemented.
- Transmission rear supports are required for all transmission installations, except LAS and units with nodal mount clutch housings.
- Starting with the release of software #5569913 it will be acceptable to configure a vehicle for a J1939 Start Enable Type in place of a Start Enable Relay. Refer to Start Enable Requirements in the Electrical System Interface section.

- An intelligent start gear selection system automatically selects appropriate gear based on percent grade, vehicle weight and engine torque. The OEM is required to perform a grade sensor calibration procedure upon initial vehicle start up to support this system.
- A PTO input is available on this transmission. The OEM is recommended to provide a connector and wiring from the transmission ECU 38-way with the PTO wires installed.
- A remote throttle enable relay is required in instances when a remote throttle is specified. The use of this system requires the OEM or body builder to install an interlock relay to interact with the Remote Throttle Enable output.
- A Low Capacity Inertia Brake (LCIB) is located coaxial about the transmission input shaft. This device is installed by Eaton. Therefore, a clutch brake is not required to be installed by the OEM. This frees up both the 6 and 8-Bolt PTO options.
- This system requires passive sealing on the clutch housing to ensure no foreign debris enters the clutch area. This requires the OEM ensure that all openings in the flywheel housing are plugged.
- A 14 tooth spline on the input shaft is standard for all transmission models.
- An auto neutral feature is required with this transmission which forces neutral in all instances when the parking brake is applied. This requires the OEM to install and connect a pressure switch in the parking brake valve circuit. Starting with the release of software #5569892, a data link signal will be an acceptable substitute for the pressure switch requirement.
- A direction sensor is a new device for this transmission which integrates the speed and directional signal into one sensor, thereby requiring only one opening (10 o'clock position) on the rear bearing cover.
- A 12 or 24 volt electrical system with a minimum of 1800 CCA is required.
- Product-specific J1939 messaging.

OEM Plant Serviceability

⚠ WARNING

If transmission removal is necessary the ECA must first be released from the clutch by one of two methods. The first method would be to use ServiceRanger. Go into Advanced Product Functions, select ECA clutch service utility. This page will give instructions for a variety of operations, you will want "Move to Service Position" click next. once you are in the Electronic Clutch Actuator service utility select the button that says Move to Service Position. This will rotate the clutch fork to the open position where the transmission can be pulled back from the engine with out damaging the clutch.

The other option is to remove the ECA by following the instructions in the ECA section.

Suggested Tools/Publications

O.E. Tool & Equipment Group/Kent-Moore SPX Corporation 1(800) 520-2584

Kent-Moore Part no.	Description
5505027	Volt/Ohm Meter (Standard commercially available VOM)

O.E. Tool & Equipment Group/Kent-Moore SPX Corporation 1(800) 328-6657

Kent-Moore Part no.	Description
J-43318	Eaton Test Adapter Kit

Liberty Circuits Corporation (269) 226-8743

Part No.	Description
500-432	Pull-To-Neutral Box
500-442	Grade Sensor Calibration Box

Eaton Service Parts 1 (800) 826-HELP (1-800-826-4357)

Part No.	Description
T-100432	Clutch Alignment Tool, 14T, 2"

Deutsch 951-765-2250

Part No.	Description
DTT-20-02	Hand Crimping Tool - Low Power Pins (size 20)
DTT-12-00	Hand Crimping Tool - High Power Pins (size 12)

Service Publications

TRSM0930	Service Manual for External components
TRTS0930	Troubleshooting Guide
TRDR1110	Drivers Instructions

Dearborn Group Technology

Part No.	Description
DG-DPA IV PLUS	Protocol Adaptor

Nexiq Technologies

Part No.	Description
104004	Pro-link GRAPHIC Scan Tool
6006001	HD Scan Tool Kit

For more information contact your OEM quality representative.

Vendor List

Eaton Vehicle Controls Business Unit

J1939 Auto Shift Display
Contact Phone Number: 919 202 5220
www.commercialcontrols.eaton.com

BELDEN WIRE AND CABLE

(HIL and J1939 Cable)
P.O. Box 1980
Richmond, IN 47375
(317) 983-5200
Fax (765) 983-5294
www.Belden.com

BRAND-REX CO.

(J1939 Cable)
300 Brickston Square
Andover, MA 01801
(978) 933-5100
www.brand-rex.com

CHAMPLAIN CABLE CO.

(J1939 Cable)
12 Hercules Dr.
Colchester, VT 05446
(802) 655-2121
Fax (802) 654-4224
www.champcable.com

DEUTSCH

(Connectors)
Industrial Products Division
37140 Industrial Ave.
Hemet, CA 92545
(909) 765-2250
Fax (909) 765-2255
www.deutschipd.com
www.laddinc.com (Ladd Industries)

PACKARD Electric

(Connectors)
Pioneer-Standard Electronics, Inc.
Packard Branch
5440 Naiman Parkway
Solon, OH 44139
1-800-PARKARD (722-5273)
Fax (219) 378-6650
www.delphiconnect.com

RAYCHEM

(Wire)
Electronics OEM Components Division
300 Construction Drive
Menlo Park, CA 94025-1164
1-800-260-9909
Fax United States (800) 260-9999
Fax Worldwide (650) 361-5579
www.raychem.com

LIBERTY CIRCUITS CORPORATION

630 East Walnut
Kalamazoo, MI 49007
(269) 226-8743

Vehicle Space Claim

Cab Floor Access Plate Requirements

Note: Refer to the “Transmission Component Temperature Requirements” on page 28.

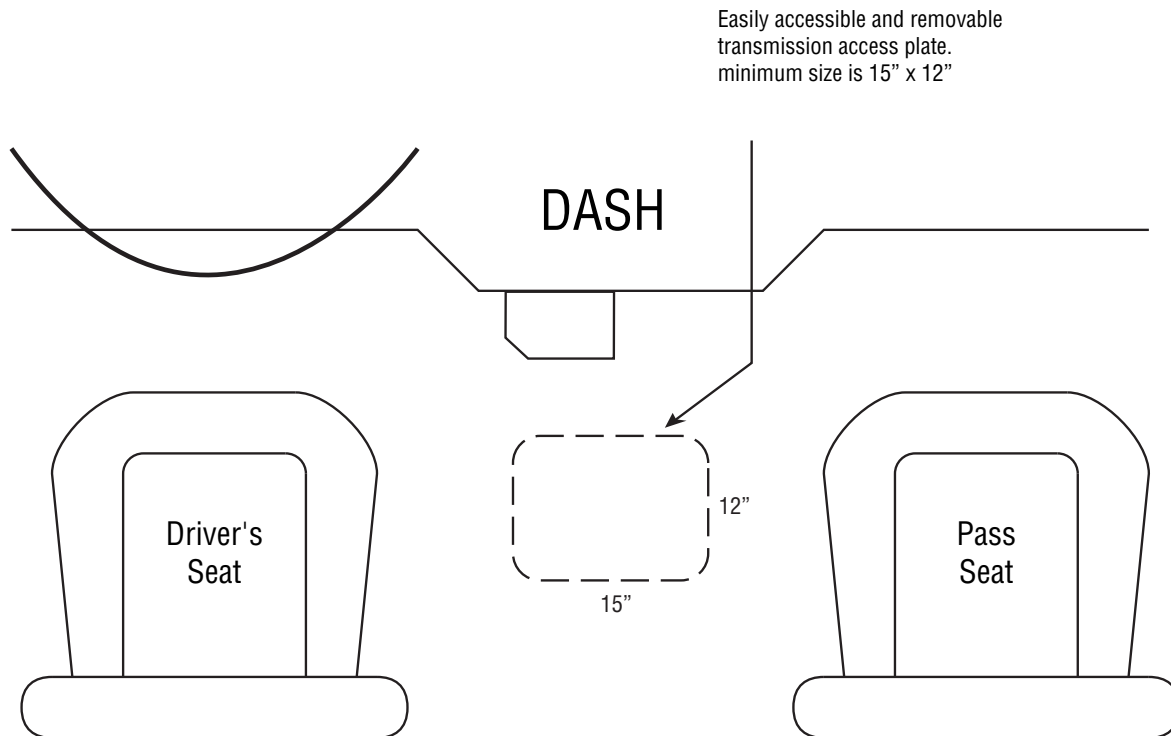

Cab Floor Access Plate Requirements

1. A cab floor access plate is required for access and removal of components from the transmission top. Plate size (minimum: 15"x12") shall be sufficient to allow removal of the Transmission Electronic Control Unit or the Electric Shifter.

Shift Label Requirements

1. The shift label should be located in the cab so that it is visible in the driver seat.
2. Shift labels are available for multiple shift devices in French, Spanish, and English.
3. The OEM must match the label with the installed shift device.

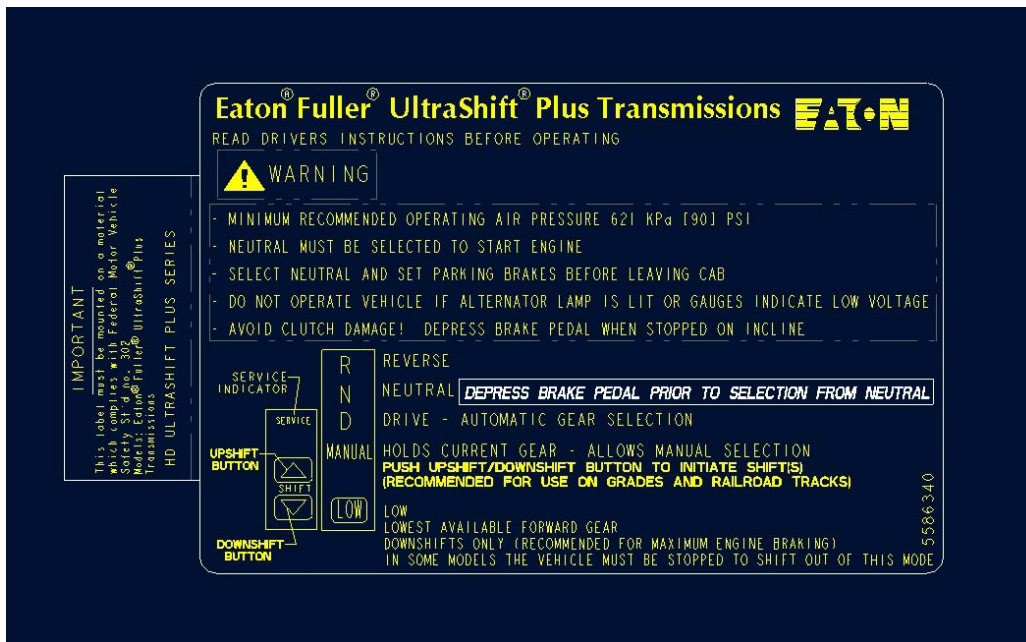
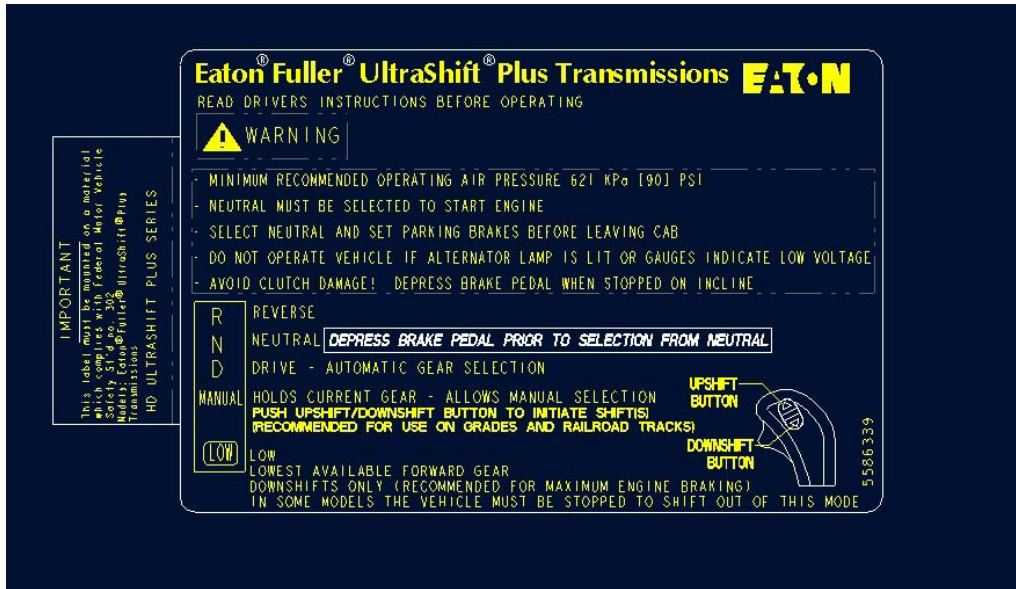

Vehicle Space Claim

Eaton Shift Console Space Requirements

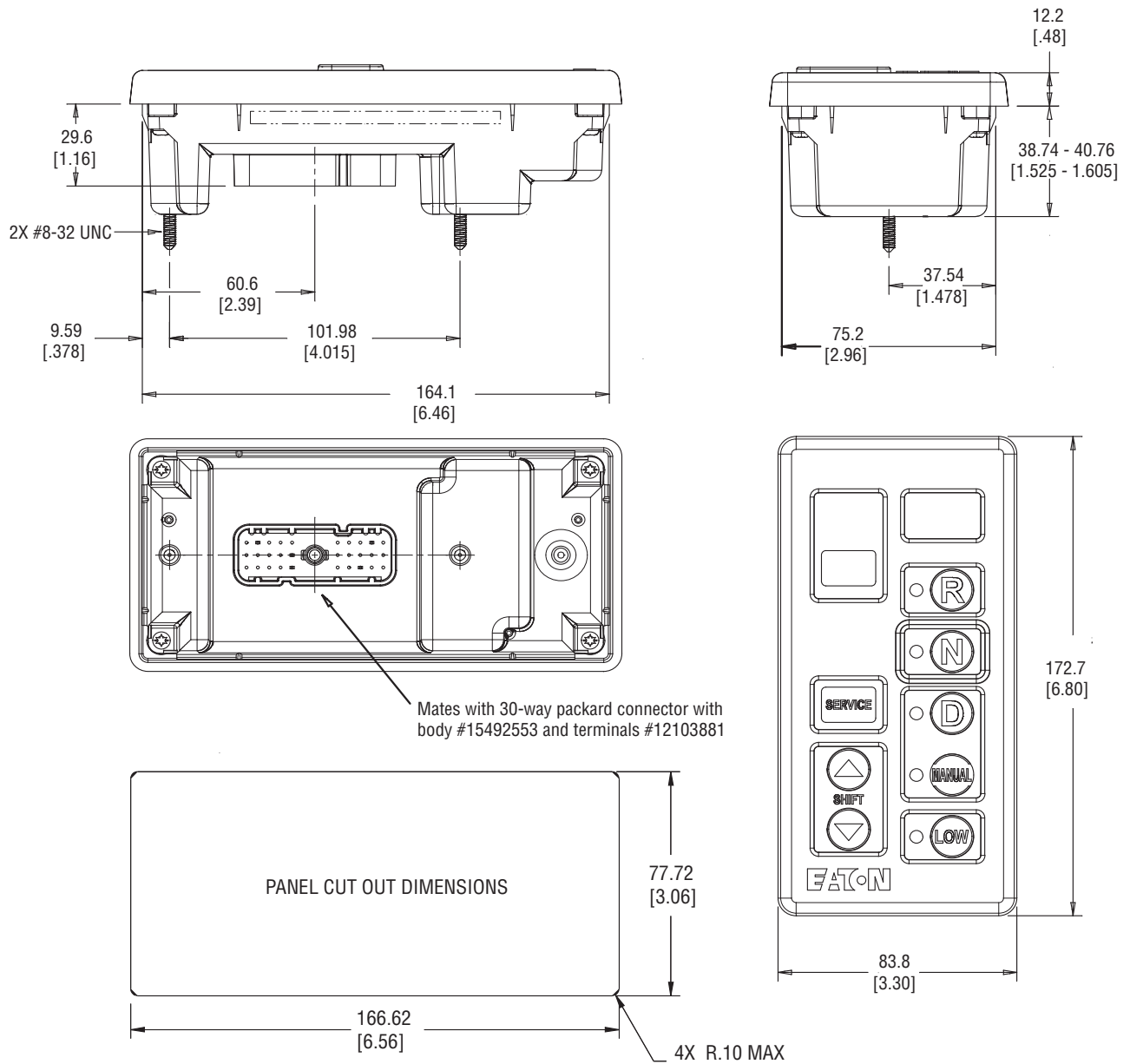

Eaton Shift Lever and Tower Space Requirements

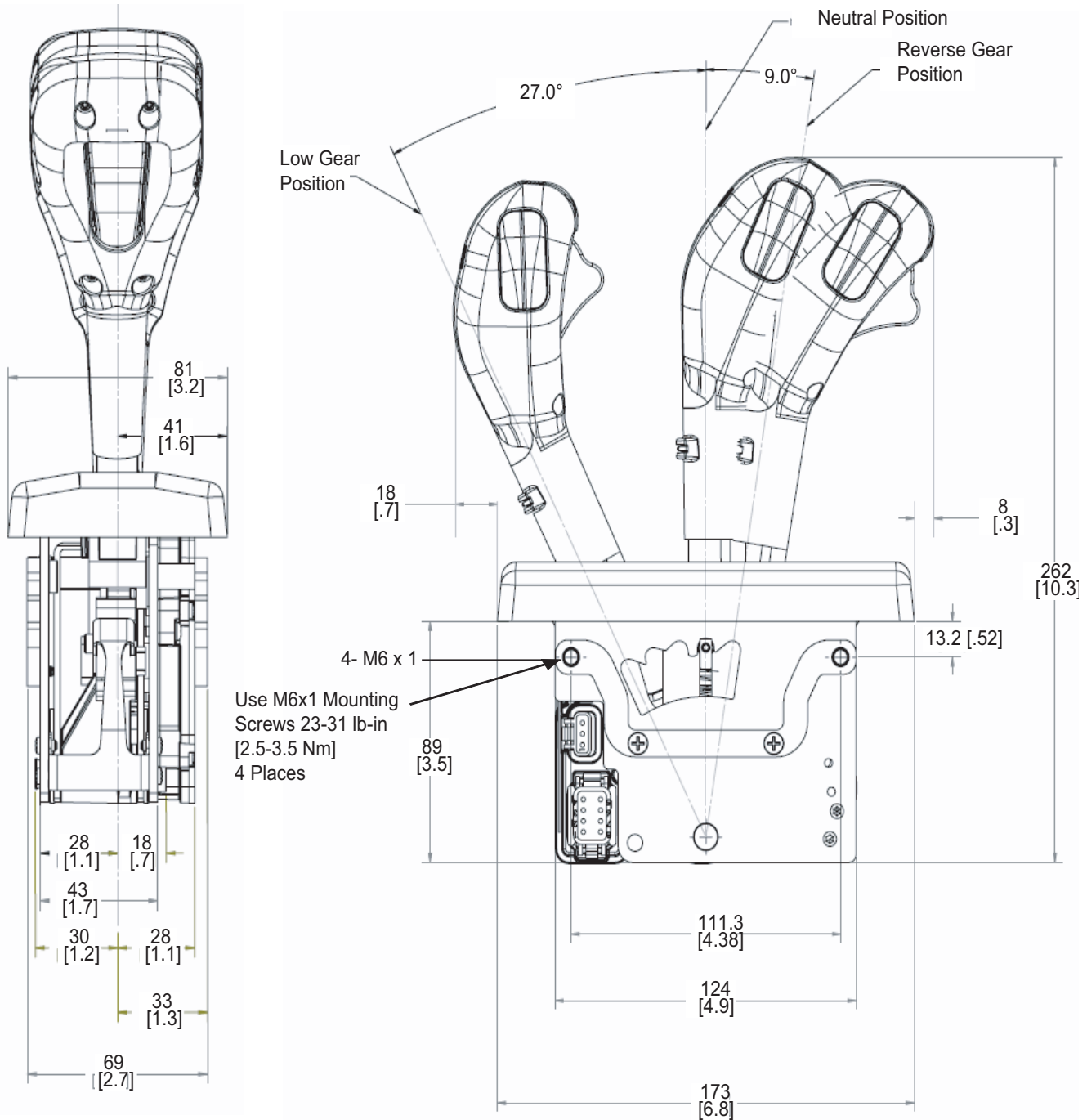

Vehicle Space Claim

Vehicle Space Claim

Fuller UltraShift® PLUS Linehaul Active Shifting (LAS) and Fuller UltraShift® PLUS Vocational Active Shifting (VAS)

Fuller UltraShift PLUS vocational models [Vocational Multipurpose Series (VMS), Vocational Construction Series (VCS), Vocational Extreme Performance (VXP), Vocational Active Shifting (VAS), Vocational High Performance (VHP) and Multipurpose Extreme Performance (MXP)] come standard with a PTO pump mounting bracket. This bracket will eliminate the need to remove any other fasteners from the transmission for mounting purposes.

Note: The PTO pump mount bracket is optional on all other Fuller UltraShift PLUS models [Multipurpose High Performance (MHP), Linehaul Active Shifting (LAS) and Linehaul Short Step Shifting (LSE)]



Eaton does not allow removing fasteners from any gasketed surface as the potential for leaks is created by doing so.

Bracket P/N 4306528

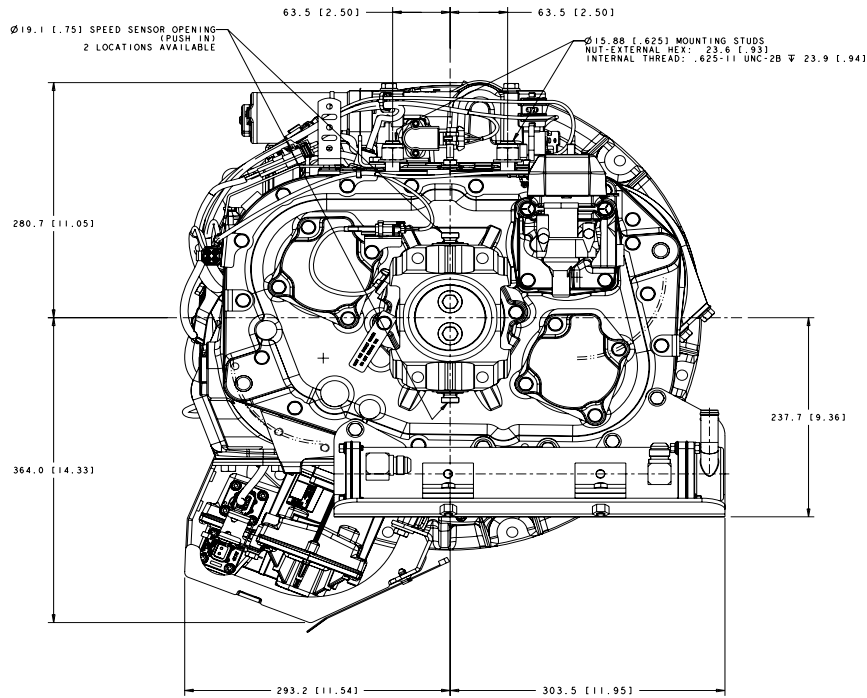

Vehicle Space Claim

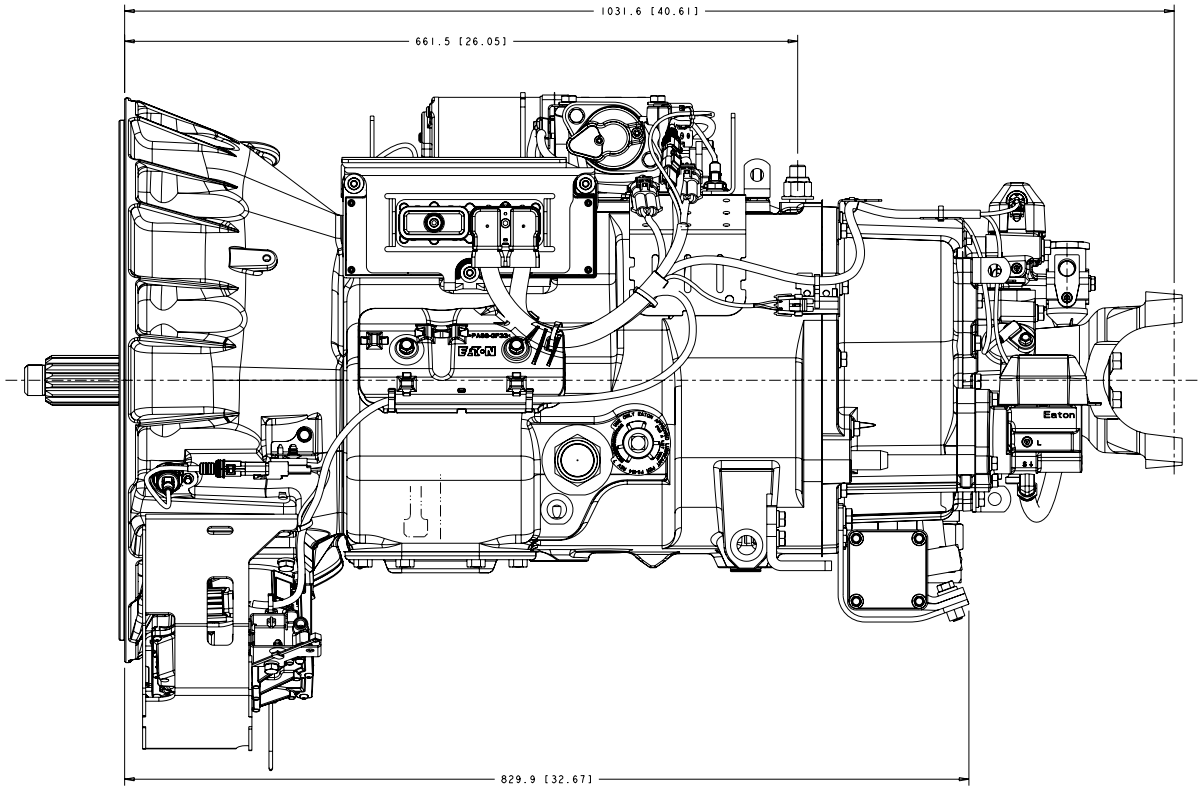

Fuller UltraShift *PLUS* Vocational Multipurpose Series (VMS) and Fuller UltraShift *PLUS* Vocational Construction Series (VCS)

Fuller UltraShift *PLUS* vocational models [Vocational Multipurpose Series (VMS), Vocational Construction Series (VCS), Vocational Extreme Performance (VXP), Vocational Active Shifting (VAS), Vocational High Performance (VHP) and Multipurpose Extreme Performance (MXP)] come standard with a PTO pump mounting bracket. This bracket will eliminate the need to remove any other fasteners from the transmission for mounting purposes.

Note: The PTO pump mount bracket is optional on all other Fuller UltraShift *PLUS* models [Multipurpose High Performance (MHP), Linehaul Active Shifting (LAS) and Linehaul Short Step Shifting (LSE)]



Eaton does not allow removing fasteners from any gasketed surface as the potential for leaks is created by doing so.

Bracket P/N 4306528

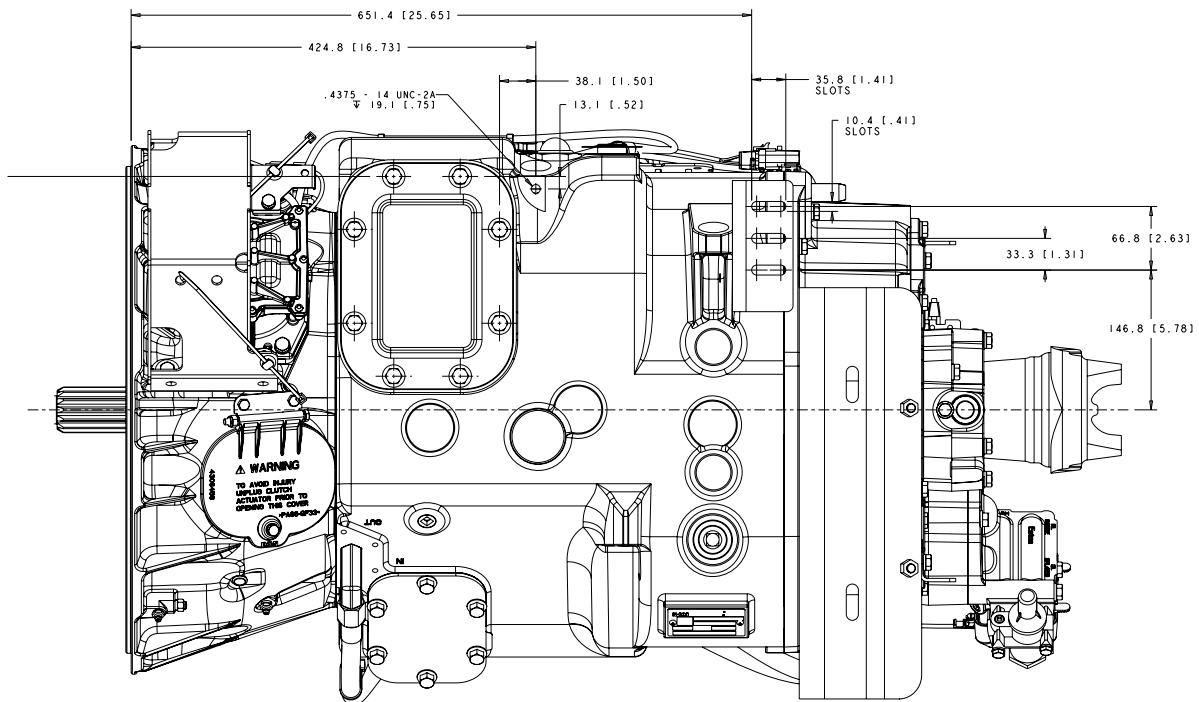

Vehicle Space Claim

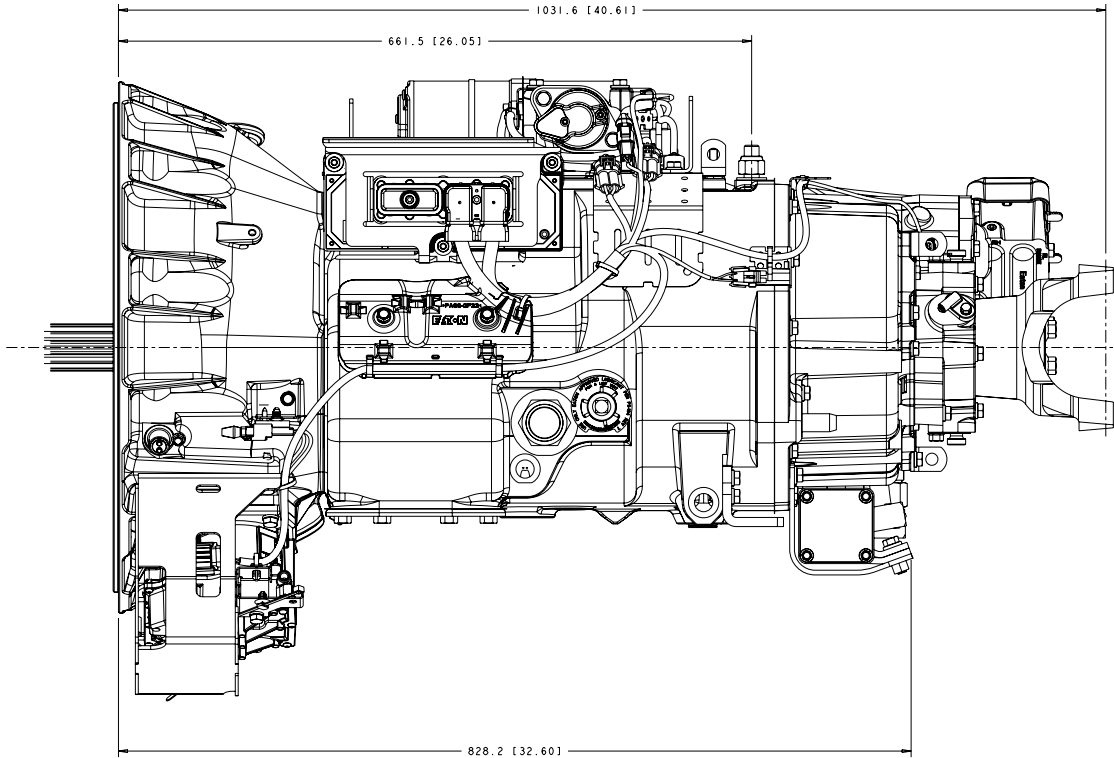
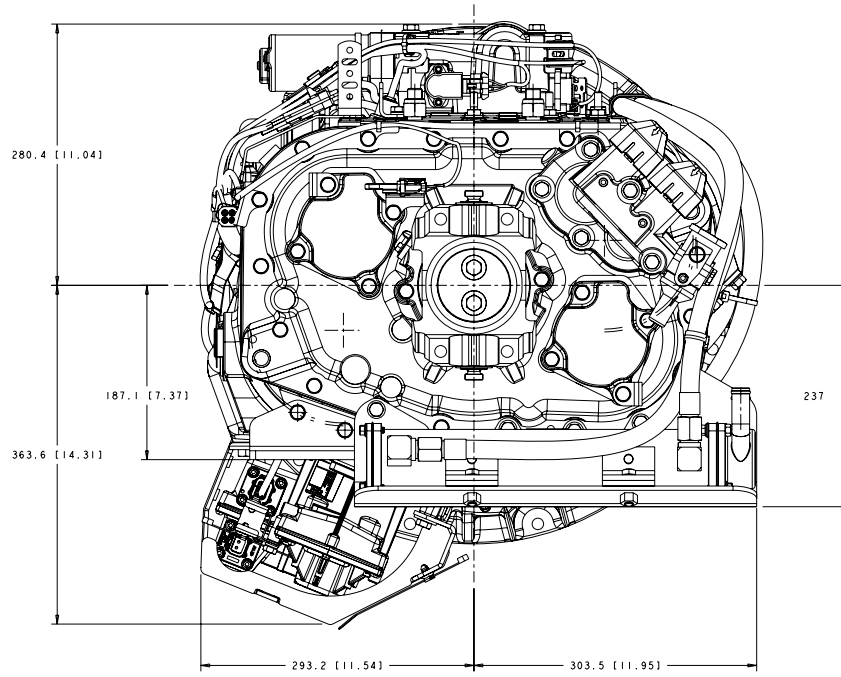

Vehicle Space
Claim

**Fuller UltraShift PLUS Vocational Extreme Performance (VXP),
Fuller UltraShift PLUS Multipurpose Extreme Performance (MXP),
Fuller UltraShift PLUS Multipurpose High Performance (MHP),
Fuller UltraShift PLUS Vocational High Performance (VHP), and
Fuller UltraShift PLUS Linehaul Small Step Efficiency (LSE)**

Fuller UltraShift PLUS vocational models [Vocational Multipurpose Series (VMS), Vocational Construction Series (VCS), Vocational Extreme Performance (VXP), Vocational Active Shifting (VAS), Vocational High Performance (VHP) and Multipurpose Extreme Performance (MXP)] come standard with a PTO pump mounting bracket. This bracket will eliminate the need to remove any other fasteners from the transmission for mounting purposes.

Note: The PTO pump mount bracket is optional on all other Fuller UltraShift PLUS models [Multipurpose High Performance (MHP), Linehaul Active Shifting (LAS) and Linehaul Short Step Shifting (LSE)]



Eaton does not allow removing fasteners from any gasketed surface as the potential for leaks is created by doing so.

Bracket P/N 4306528

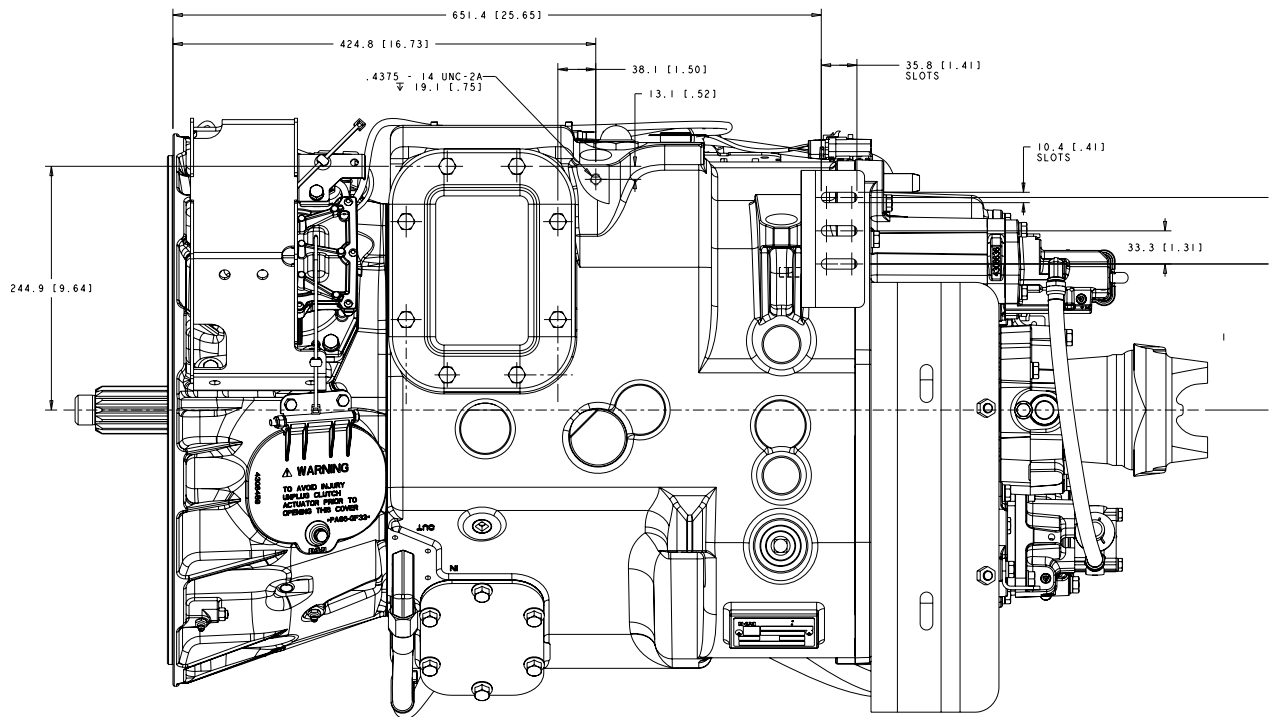

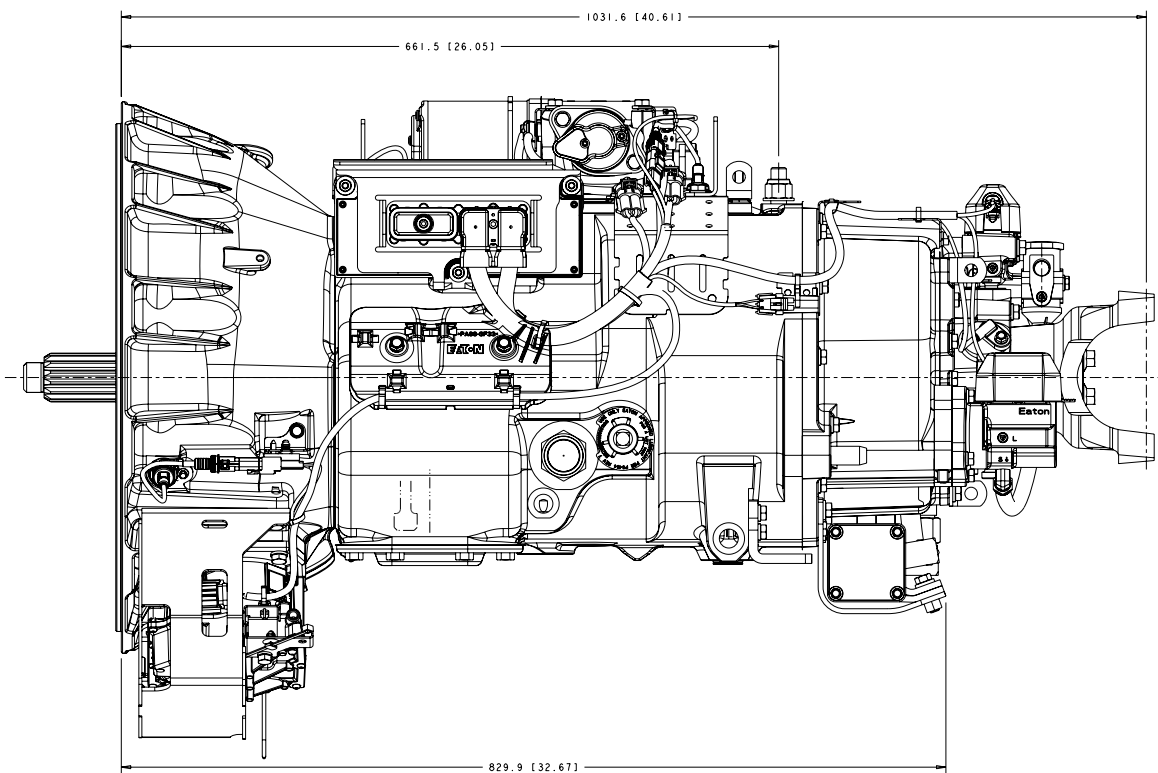
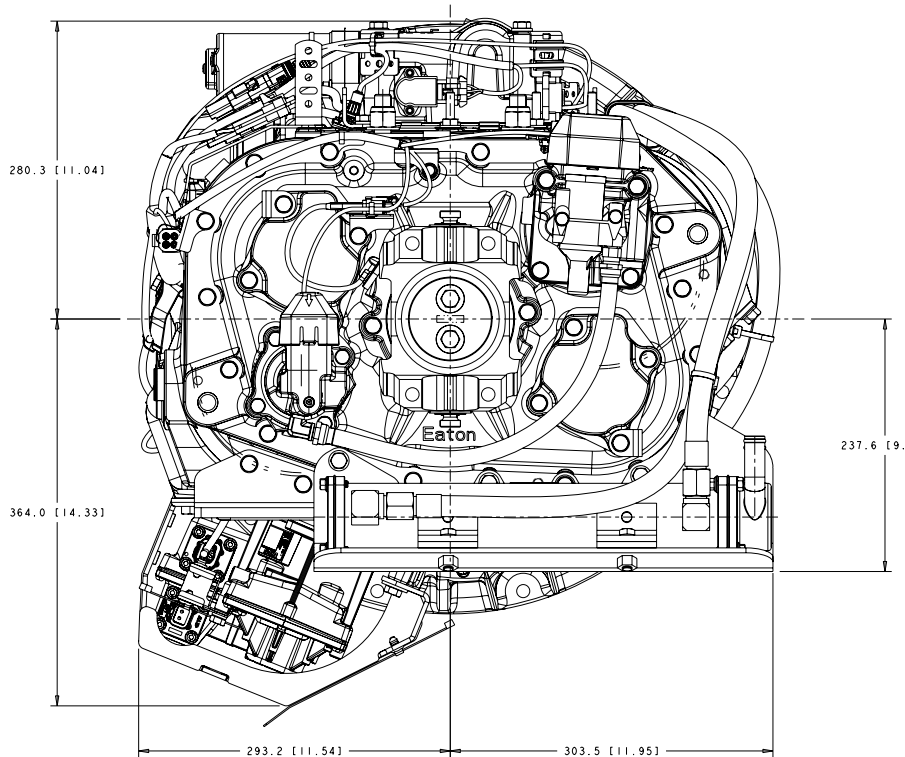

Clutch Interface

Pilot Bearing Specifications

The OEM is responsible for the design and selection of pilot bearings to mate with our product. Eaton recommends high quality pilot bearings procured from Original Equipment Manufacturers. Significant decrease in life may occur with the use of generic brand pilot bearings.

The following pilot bearings are currently the minimum Eaton Clutch Division recommends. The operating temperature that the pilot bearing sees has increased in the last several years. This creates operating conditions that are no longer acceptable to the standard pilot bearings and grease. In addition, the life of the clutch has increased. The use of high temperature grease and Viton seals are now mandatory to ensure adequate bearing life. Pilot bearing failure usually results in a warranty claim for drag or clutch noise. This results in a claim against Eaton Clutch.

Below is a list of the recommended Pilot Bearings. All of these bearings have Viton seals and a high temperature grease in addition to a C3 fit. It is acceptable to use synthetic high temperature grease and a C5 fit if desired.

Vendor	Seal Type	Bearing Series 6205	Bearing Series 6306	Bearing Series 6006
NTN	Viton	6205 LLUA1/C3	6306 LLUA1/C3	6006 LLUA1 C3/LX16
KOYO	Viton	6205 2RKF-S2/C3	6306 2RKF-S2/C3	-
NSK	Viton	6205 DDU7/C4 ENS	6306 DDU7/C4 ENS	6006 DDWA18A C4/ENSS
SKF	Viton	6205 2RS2/C3	6306 2RS2/C3	-
FED-MOG	Viton	6205 VV/C3	6306 VV/C3	-
PEER	Viton	6205-2VRLD-C3	6306-2VRLD-C3	6006-2VRLD-C3

Grease Hose

P/N 4306950 Sold as loose part.

Insert the grease hose into the pre-installed push to connect fitting in the clutch release bearing. As the transmission is being brought up to the engine stick the hose through the grommet in the clutch housing next to the cross shaft grease hose. As the transmission is moved closer to the engine continue to lightly pull the hose, this will keep the hose from getting caught inside the clutch housing. Once the transmission is bolted to the engine with an approved cutter, using care to make a clean cut that will not damage the O-ring in the push to connect fitting, push the hose into the pre installed push to connect fitting on the outside of the clutch housing.

Note: Air must be purged from the grease hose. This will take approximately 5 ml or 5 to 6 pumps of a typical grease gun.

ECA Clutch Installation

Clutch Requirements - All Fuller UltraShift *PLUS* model transmissions (VCS, VMS, VXP, MXP, MHP and LAS) require an adjustment free ECA UltraShift clutch. This clutch is different than the standard adjustment free clutch used in the current AutoShift heavy-duty product. Two different part number ECA clutches are available:

1. Up to 1850 lb-ft rating (P/N 122002-35)
2. Up to 2250 lb-ft rating (P/N 122003-42)

Installation Instructions

- Install two guide studs into the upper mounting holes. Be sure to use guide studs to ensure proper alignment of the clutch assembly to the flywheel.
- Use a lifting device to pick up clutch.

Note: The intermediate plate is bolted to the cover assembly and the rear disc is in between the pressure plate and the intermediate plate. Do not unbolt the intermediate plate from the cover assembly.

- Insert aligning tool through bearing and splined strapped driven disc.

Note: The alignment tool for the ECA UltraShift clutch is a 14-tooth shaft and is 1-3/4" longer. A modified input shaft (P/N 4306034) can be used as an alignment tool or tool number T-100432 shown in Appendix can be used to manufacture a tool.

- Install second disc onto aligning tool. Follow the orientation instructions on the disc.
- Slide the clutch assembly over the guide studs and start six of the clutch mounting bolts. Start at the lower left when tightening the clutch mounting bolts. This will ensure that the clutch is properly pulled into the flywheel pilot. Failure to do this could result in improper piloting of the clutch and cause clutch damage. Tighten the clutch mounting bolts in a crossing pattern to 40-50 ft lbs (54-68 Nm) as on any other clutch. Remove the guide studs and install the two remaining bolts.
- Remove shipping bolts in an even 1/4 turn crossing pattern.
- Remove the alignment shaft.
- The release bearing shall be positioned so that the orientation of the lube fitting/hose is in the 4 o'clock position.

Note: No initial clutch adjustment required.

ECA Removal and Assembly Instructions

If transmission removal is necessary the ECA must first be released from the clutch by one of two methods.

The first method is to use ServiceRanger:

1. Go into Advanced Product Functions and select ECA clutch service utility. This page will give instructions for a variety of operations.
2. Select "Move to Service Position" and click next.
3. Once in the Electronic Clutch Actuator service utility, select the button that says "Move to Service Position". This will rotate the clutch fork to the open position so the transmission can be pulled back from the engine without damaging the clutch.

The other option is to remove the ECA by using the following instructions. Refer to the following procedure in the event the Electric Clutch Actuator assembly requires removal and replacement:

ECA Removal:

- Cut tie straps which secures the ECA harness (if applicable)
- Disconnect the harness to the ECA
- Remove the (4) 3/8"-16 capscrews that secure the ECA bracket. Remove the bracket.
- Remove the (4) 3/8"-16 capscrews that secure the ECA to the housing. Remove the ECA. The ECA will need to be rotated to line up a locating pin with a notch in the housing in order to remove the ECA from the clutch housing.

ECA Installation

- Ensure the clutch fork is positioned against the stop.
- Apply anti-seize compound to the bore of the ECA.
- The ECA will need to be rotated to line up a locating pin with a notch in the housing in order to install the ECA into the clutch housing.
- Install the ECA onto the housing, while matching the splines of the ECA motor to the shaft.
- Install (4) 3/8"-16 capscrews to secure the ECA to the housing. Torque to 25-35 ft lbs.
- Install (4) 3/8"-16 capscrews to secure the ECA support bracket with applying loctite 242 to the threads. Torque cap-screws to 25-35 ft lbs.
- Reconnect the appropriate wire connectors.
- Replace tie straps that secure harnessing.

Split Dimension

Note: The Split Dimension for all Heavy Duty UltraShift Plus models is 63.5mm

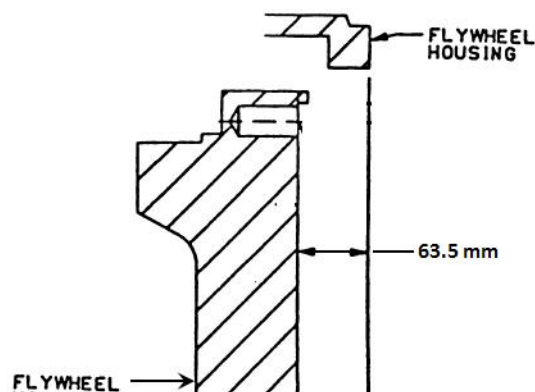

Transmission Interface

Handling

Handle the transmission carefully to avoid damage to the transmission components and surrounding vehicle components.

- Use a hoist or transmission jack that permits precise control of the transmission movement during installation.

Transmission Preparations

Note: Eaton has provided several brackets that can be used for clipping vehicle components to. ECU, sensor, and lifting eye fasteners are not to be used for securing additional OEM brackets under any circumstances. This includes cap screws used to fasten the shift bar housing, rear housing, bearing covers, and PTO covers. Removal of these can compromise transmission system operation and overall system reliability.

Note: No mechanical speedometer. The rear bearing cover will offer three (3) push-in sensor openings at 6, 10, and 12 o'clock positions. The 10 o'clock position is reserved for Eaton for the direction and speed sensor assembly. The 6 and 12 o'clock positions are reserved for the OEM to install a speed sensor. The tone wheel has 16 teeth, as standard.

Reverse and Neutral Switches

Reverse and Neutral Switch Options

Reverse and neutral switch openings are standard on all heavy duty Fuller transmissions. The transmission will be shipped with plugs in these openings, unless switches are ordered by the OEM and pre-installed by Eaton.

Reverse Switch

Location: Opening is located at the rear of the shift bar housing. See top view drawings for location.

Switch type: Normally open ball type switch.

Thread size: 0.5625-18 UNF-2B.

Mating Connector: Options are screw terminals or Weather Pack.

Neutral Switch

Note: The transmission neutral switch provides an indication of neutral, but does not guarantee a true neutral position or provide a "confirmed neutral" output. This switch shall not be used as the sole indication that the transmission is in neutral.

Location: Opening is located on the left side of the shift bar housing. See top view drawings for location.

Switch type: Normally open ball type switch.

Thread size: 0.750-16 UNF-3B.

Mating connector: Options are screw terminals or Weather Pack.

End Yoke Retaining Design

All Fuller UltraShift *PLUS* model transmissions (LAS, LSE, MXP, MHP, VAS, VCS, VHP, VMS and VXP) have a two bolt retainer plate design to fasten and retain the end yoke. These transmission will be shipped with end yokes installed. A dual spindle driver is recommended to install the yokes. If a dual spindle is not available, special care shall be exercised to snug each bolt to 35 ft-lbs prior to attaining full torque of 74 -81 ft-lbs. For reference, these bolts are M12 x 1.25 x 60 mm Grade 10.9 per DIN 6921.

Mounting Transmission to Engine

Use the two transmission lifting eyes provided. The lifting eye position shall not be changed on the transmission. Do not remove the Electric Shifter at any time.

- Use a two point lift chain or transmission jack with a minimum capacity of 1500 lbs.
- Inspect the engine to transmission mating surfaces for damage or debris prior to installation. Make sure the engine flywheel housing face, transmission clutch housing face, input shaft, etc. are free of paint, debris, rust, and any type of damage before installation.
- The transmission is shipped in gear until the vehicle is powered up with the key switch. Use a Pull-to-Neutral-Box to disengage the transmission or rotate the axles to align the transmission prop shaft.
- Input Shaft To Clutch Alignment - the transmission is shipped from Eaton with the transmission in gear. The transmission shall be in gear in order to rotate the input shaft by turning the output shaft/yoke. The transmission will automatically reset to the neutral position as soon as the vehicle is powered up (key switched on). In the event that the transmission is not received in gear, the input shaft will have to be manually indexed to mate up with the clutch splines.
- Transmission is shipped from Eaton with the ECA in the fully retracted position, allowing clearance for the release bearing. Ensure the grease fitting on the release bearing is at approximately the 4 o'clock position to allow installation of the of grease tube.
- Adjust the lift chain or transmission jack to obtain the same relative angle as the engine. The face of the engine flywheel housing and the face of the transmission clutch housing shall be parallel during installation. Rotate the output shaft/yoke while sliding the input shaft into the clutch to line up the splines. If the transmission is properly aligned and the clutch splines are properly aligned, very little force is required to slide the input shaft through the clutch and into the pilot bearing.
- If interference is encountered, move the transmission away from the engine to investigate the cause. The use of excessive force to overcome misalignment may cause damage to the transmission input shaft and the clutch.
- The clutch/yoke will remain in the released position during the entire transmission installation. At key on the ECA will rotate the clutch/yoke to its proper position.
- Once the transmission is seated against the engine flywheel housing, align the clutch housing bolt holes with the engine flywheel housing bolt holes and install all capscrews and tighten finger tight.

Note: The clutch housing shall be flush against the engine flywheel housing before tightening any capscrews. Do not use the capscrews to seat housing.

- The ECA and ECA cover will be shipped with the transmission to the OEM. This requires a change to the fastening procedure. Initially tighten (4) capscrews 90 degrees apart starting with the capscrew immediately above the ECA. Then tighten the remaining (8) capscrews.

Note: The use of a swivel socket may be required for the (2) bolts entering through the ECA device.

Note: Do not tighten any mounting capscrews until all capscrews have been installed and finger tightened. Do not remove the transmission support chain or jack until all mounting bolts have been tightened.

Using Rear Supports

Transmission rear supports are required for all Fuller UltraShift *PLUS* model transmissions (LAS, LSE, MXP, MHP, VAS, VCS, VHP, VMS and VXP) installations, except LAS and units with a nodal mount clutch housings.

Air Supply and Air Drying Requirements

- It is required to use a high quality commercially available air dryer in the air supply line before the transmission.
- Minimum air requirement for the transmission is 65 PSI [4.481] bar, except on LAS models which require 80 PSI.
- A minimum of 1/4" i.d. [.635 cm] diameter air supply line is required.
- The transmission air supply is required to be routed from the air tank, which supplies air to either the front or rear vehicle service brakes, with a gauge indicator in the cab.
- Transmission airlines should not be routed or attached at the bottom air tank fittings to avoid any chances of introducing moisture into the airline.
- Care should be used when routing the air supply to avoid kinks and close contact to heat sources.
- The transmission air supply shall be connected to the air filter/regulator mounted on the range cylinder cover.
- Air additives such as alcohol devices should not be permitted to enter the transmission air supply. Additives could cause damage to air system components, which could lead to degraded transmission performance.

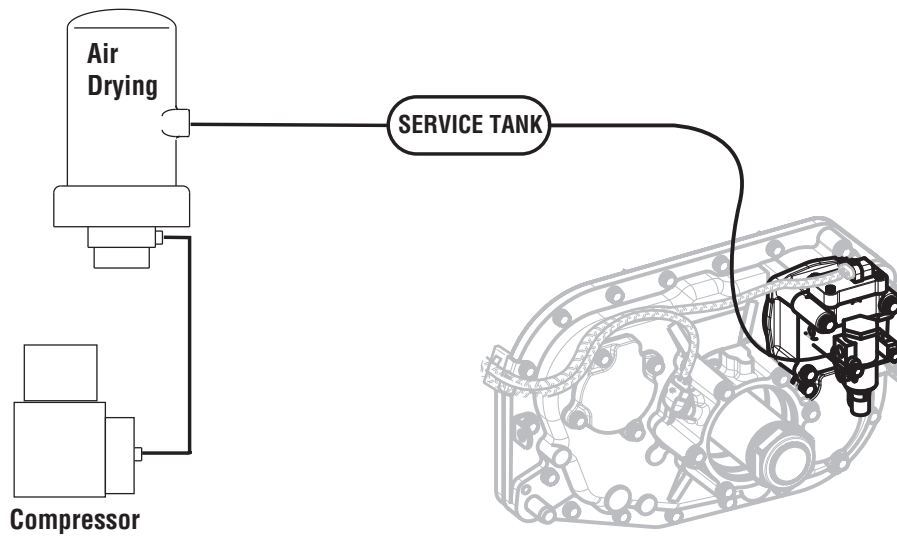

Lubrication Requirements and Specifications

Fuller UltraShift *PLUS* (LAS, LSE, MXP, MHP, VAS, VCS, VHP, VMS, and VXP) Transmission Gear Box Lubrication Requirements

Eaton requires the use of a transmission lubricant that meets PS-386 specification.

A list of approved lubricants and suppliers can be found in the Approved Lubricant Supplier Manual, TCMT0020.

Not using the required lubricant will result in degraded performance and shortened life of the product. Refer to the Lubrication Manual, TCMT0021, for the latest information regarding lubrication requirements.

Note: Eaton recommends the use of Eaton Roadranger Lubricants. Roadranger SAE 50 Synthetic Lubricant and Eaton PS-386 are the only approved synthetic lubricants.

Note: Failure to adhere to Eaton installation requirements may affect the transmission performance and / or warranty coverage.

Required Lubricant
Transmission Gear Box - Eaton Roadranger SAE 50 Synthetic Lubricant or PS-386 approved lubricant.

Warnings and Cautions

- Before working on a vehicle, place transmission in neutral, set brakes, and block wheels.
- Do not introduce additives and / or friction modifiers. Additives of any kind added later to the oil can result in unpredictable consequences. No liability of any kind will be accepted by Eaton for any damage resulting from the use of such additives.
- Do not mix lubricants of different grades.
- Use clean containers when transferring lubricant from the bulk storage to the transmission. Containers used for anti-freeze or water should be cleaned prior to use.
- Do not re-use lubricant.
- Failure to use the required lubricant will affect the transmission performance and the warranty coverage.
- SAE 15W-40 viscosity grades are not allowed in Eaton transmissions.

Operating Temperatures

Transmissions must not be operated at temperatures above 250° F (121° C.) Operation at temperatures above 250° F (121° C) causes loaded gear tooth temperatures to exceed 350° F (177° C) which will ultimately destroy the heat treatment of the gears.

The following conditions in any combination can cause operating temperatures over 250° F (121° C.)

- Operating consistently at high loads / slower speeds
- High ambient temperatures
- Restricted air flow around transmission
- Exhaust system too close to the transmission

Transmission Oil Level

Note: Before checking oil level, engine must be idling in neutral for at least two minutes and lubricant temperature must be between 60° F and 120° F (15.5° C and 48.8° C.) This will ensure that all oil coolers are filled.

Transmission Capacity (Approximate)	
VCS, VMS, VXP, MXP, MHP, LSE, VHP	28 pints (13 liters)
LAS, VAS	26 pints (12.3 liters)

1. Place vehicle on level ground.
2. Turn engine off.
3. Remove fill hole plug.
4. Lubricant must be level with the bottom of the fill hole (+/- 3mm).
5. Reinstall the fill hole plug and torque to recommended torque value.
6. Clean off any oil residue.

Make sure that the transmission lubricant is level with the bottom of the fill opening (+/-3mm).

Note: Being able to reach the lubricant with your finger does not indicate that the lubricant is at the proper level. (On heavy-duty transmissions, one inch of lubricant equals about nine pints of oil.)

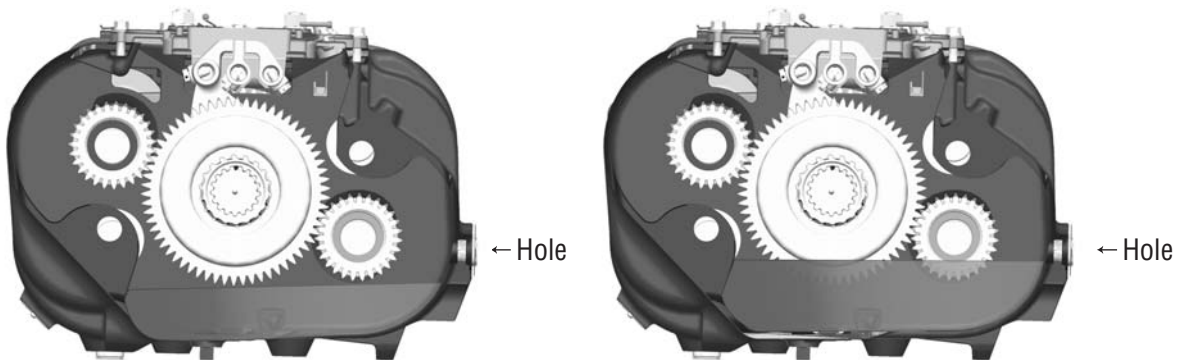

Improper Oil Level

Proper Oil Level

DO NOT remove the Electric Shifter (XY Shifter) to fill the transmission with oil. The transmission must be filled through the fill hole.

The transmission is equipped standard with an oil level sight glass. When the transmission oil level is at or above 3/4 of the sight glass then it is at or above the minimum oil fill level.

To check the oil level with the sight glass:

- Vehicle engine shall be stopped and parked on level ground.
- Wipe dirt from the oil level sight glass.
- When the transmission oil level is at or above 3/4 of the sight glass then it is at or above the minimum oil fill level.

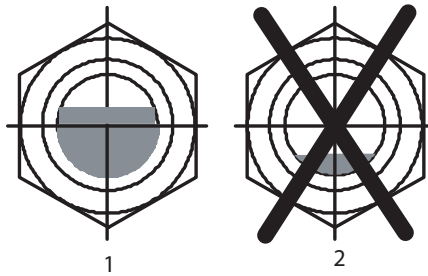

Cooler Requirements

Transmissions must not be operated at temperatures above 250°F [121°C]. Operation at temperatures above 250°F [121°C] causes loaded gear teeth temperatures to exceed 350°F [177°C] which will ultimately destroy the heat treatment of the gears. If the elevated temperature is associated with an unusual operating condition that will recur, a transmission oil cooler should be added, or the capacity of the existing cooling system increased. The following conditions, in any combination, can cause operating temperatures of over 250°F (120°C):

- Operating consistently at high/low speeds
- High ambient temperatures
- High horsepower operation
- Restricted airflow around transmission
- Excessive use of engine retarder
- Exhaust system proximity to transmission
- High power PTO operation for extensive periods while stationary
- High engine RPM for extensive periods

External oil coolers are available to reduce operating temperatures when the above conditions are encountered. Eaton Oil cooler systems must meet a minimum requirement of 3/4" water coolant lines and 8 GPM water coolant flow at 1500 RPM. The end user is ultimately responsible for maintaining transmission lube temperatures below 250°F [121°C]. Transmission oil coolers must be used to reduce operating temperatures when the above conditions are encountered.

Transmission oil coolers are recommended with engines 350 hp and above. Transmission oil coolers are required with:

- Engines 400 HP and above and 1,400 lb-ft or greater torque
- Engines 400 HP and above and a GVW / GCW over 90,000 lbs
- Engines 450 HP and above
- Engines 1500 ft-lb and above

Transmission Component Temperature Requirements

The temperature limit for all electrical and air system components is 250°F° (121°C). Do not exceeded. If sufficient air gap between the heat source and these transmission components cannot be achieved, the OEM must provide proper methods of heat shielding to ensure this limit is not exceeded. The components and systems to be protected would include, but not limited to, the Shift Motors, Sensors, Solenoids, Air Filter Regulator, Inertia Brake, Wire Harness, Transmission Controller, Oil Cooler and Hoses, ECA, and the Transmission Case.

Top View

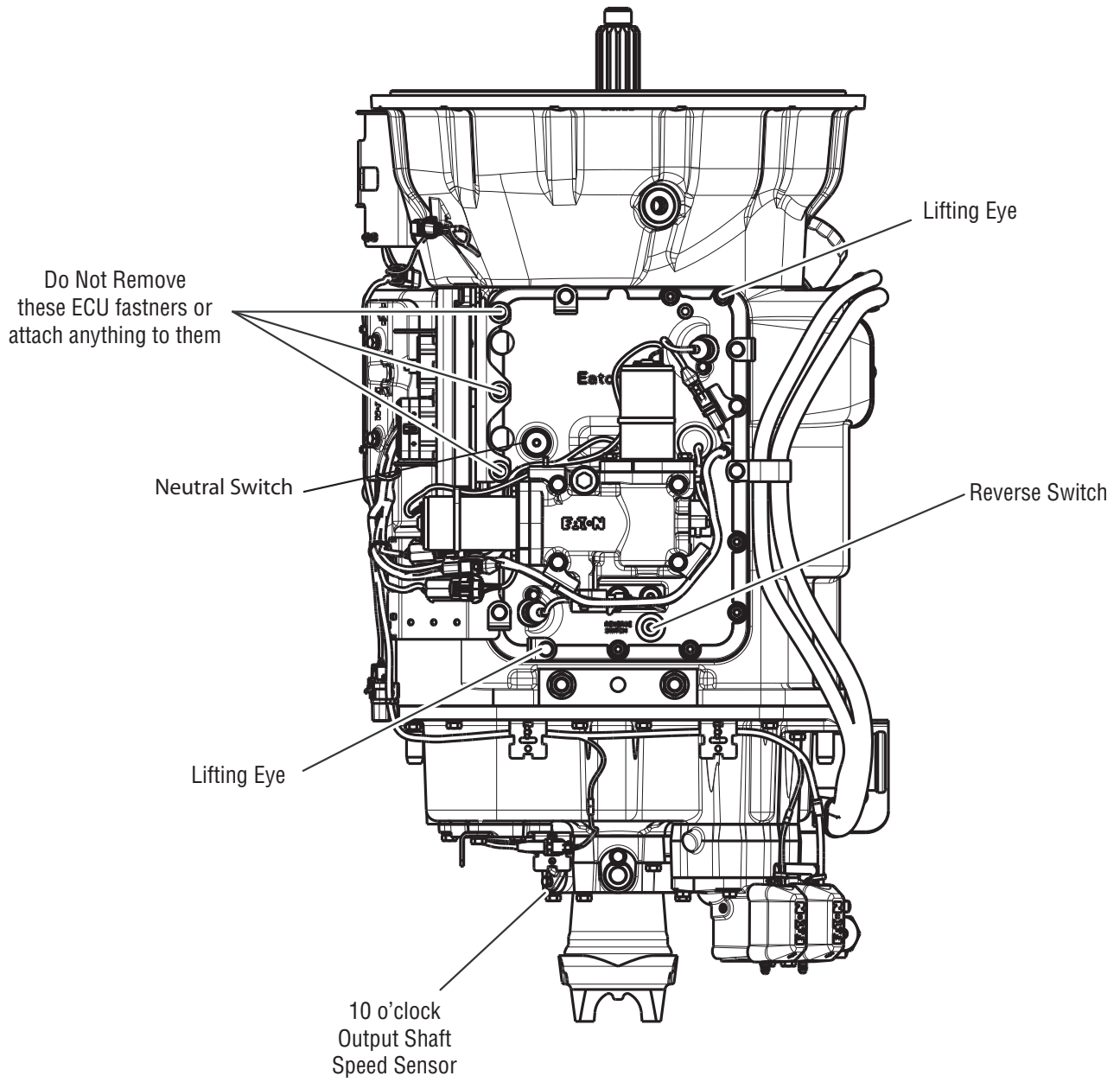

Electrical Wiring Requirements

Note: “Power” refers to both Power Positive and Power Negative supply. (This is typically Battery Plus and Battery Negative.)

Note: “Switched Ignition” refers to power that is enabled with ignition key operation.

Note: Starting in November 2015 Automated transmissions began using the Generation 2 ECA which uses a Deutsch 2-Way power harness connector system. All references in this document pertain to the Generation 2 ECA Power Pack.

Power Requirements

- The vehicle shall have a negative ground power system.
- The vehicle primary power system shall be either of the following types: 12 or 24 volt.
- It is permissible to lose power to both the Transmission Control Module (TCM) and Electric Clutch Actuator (ECA) due to a single point disconnect, ONLY IF that same single point disconnect ALSO removes power to the Engine Control Module (ECM) simultaneously. (This is typically performed via a power distribution panel.)
- If a disconnect switch is used for the ECM, it shall be configured such that it also removes power to the TCM and ECA.
- The OEM shall provide power wiring to the TCM such that the differential voltage (TCM negative subtracted from TCM positive) shall exceed 9 volts DC at a steady state load of 30 amps as configured for a 12 volt base system (18 volts DC at a steady state load of 30 amps as configured for a 24 volt base system.)
- The OEM shall provide power wiring to the transmission ECA such that the differential voltage (ECA positive minus ECA negative) shall exceed 9 volts DC at a steady state load of 40 amps as configured for a 12 volt base system (18 volts DC at a steady state load of 40 amps as configured for a 24 volt base system.)
- The OEM shall supply power to the TCM that does not exceed a steady state voltage of 32 volts DC.
- The OEM shall provide switched ignition power to the TCM such that it provides 10 amps at 12 volts DC.
- Power and switched ignition to the TCM shall not be switched off during the engine start process.
- The OEM shall include a starter relay.

Electrical Current Requirements - Operating Conditions over Temperature for 12-Volt Systems

- The Main Power 30 amp fuse connection for the TCM is required to be identified at the termination.
- The Switched Ignition 10 amp fuse connection for the TCM shall be identified at the termination.
- Operating current characteristics for the TCM:
 - Active Shifting Current = 30 amps
 - Maintaining current gear = 6 to 15 amps
 - Power down sequence = 6 to 15 amps
- The ECA Main Power 40 amp fuse connection for the ECA is required to be identified at the termination. The continuous operating current of the ECA will not exceed 30 amperes

Mating Connector and Terminal Requirements

- Connectors shall be designed for use in the heavy-duty industry, conforming to SAE-J2030 and SAE-J1455.

- The OEM harness TCM mating connector shall be DRC26-38S01-P017 or equivalent. Mating Torque shall be 25 +/- 3 lbs. in. (2.82 +/- 0.33 Nm).
- The OEM harness ECA mating connector shall be Deutsch DTP06-2S-E003 or equivalent.
- Connectors shall be fully mated.
- Connector latches shall be completely locked.
- Unused Connectors and terminal cavities shall have sealed mating connectors or plugged.
- Gold plated terminals shall be used for signal circuits.
- The TCM Deutsch connector's size 12 pins shall be nickel plated terminals and used for power circuits.
- The TCM Deutsch connector's size 20 pins shall be gold plated terminals and used for signal circuits.

Electrical Sealing Requirements

All electrical junctures outside of the cab are required to be sealed per SAE-J2030 standards.

Network Communications Requirements

- When the Eaton Push Button Shift Control is used, the Control Area Network (CAN) communications link between the Shift Control and the Transmission Controller must follow J1939/15.
- The J1939 (the communications link between the Transmission TCM and the Engine Controller (ECM) shall follow SAE J1939 specifications for either J1939/11 or J1939/15.
- Shielded Twisted Pair (STP) per SAE J1939/11 or SAE J1587 accordingly.
- Unshielded Twisted Pair (UTP) per SAE J1939/15 or SAE J1587 accordingly.
- During all operating conditions, the voltage potential between TCM negative and ECA negative, measured at the controllers, shall not exceed 2.0 volts DC.

Vehicle Service Requirements for Electronics

- Battery Positive and Negative must be disconnected PRIOR to any type of welding on any Fuller[®] Automated transmission equipped vehicles.
- Battery Negative must be disconnected PRIOR to removal or installation of TCM harness connectors.
- Removal and / or replacement of a battery shall not disturb the terminating connectors of the TCM and ECA.

Auto Neutral Requirements

An auto neutral feature is provided with this transmission which forces the transmission into neutral in all instances when the parking brake is applied. This Requires the OEM to "T" a normally-closed pressure switch into the existing air line to the parking brake valve. Contact the brake manufacturer for pressure switch requirements. The pressure switch output and return wires are connected to the vehicle interface transmission TCM connector per the table in the "Connector Pin Descriptions" section. Starting with the release of software #5569892 it will be acceptable to use a J1939 Park brake signal in place of this switch. Refer to the table in the section SAE J1939 Data Link Received Messages.

Start Enable Relay Requirements

Starting with the release of software #5569913 it will be acceptable to configure a vehicle for a J1939 Start Enable Type in place of a Start Enable Relay. A configurable Start Enable Type supports "Relay" or "J1939" control. The J1939 ETC7 SPN 2900 Transmission Crank Enable message may be used to enable cranking without a relay. This feature can be configured with VEPS or Service Ranger 4.

Remote Throttle Installation

- Remote throttle applications shall be electrically interlocked by the transmission via an interlock relay with the high side of the relay coil wired directly to pin V24 on the transmission TCM.
- The wiring shall be installed by the OEM or the bodybuilder if not already done by the OEM.
- The bodybuilder shall install the wiring such that it matches one of the options shown in the diagrams in the Aux Equipment Interface section.
- The bodybuilder shall verify proper operation prior to delivery to the customer.

Harness Routing Requirements

- Harness and in-line connectors shall be anchored to prevent free movement. An anchor point shall be no further than 6 in. [15.24 cm] (Recommended 3 in. [7.62 cm]) from a connector. The length of an unanchored section of harness should be no more than 12 in. [30.48 cm].
- Eaton has provided several brackets that can be used for clipping vehicle components to. Do not mount additional components to TCM, transmission brackets, mounting studs, or lifting eyes under any circumstances. This includes cap screws used to fasten the shift bar housing, rear housing, bearing covers, and PTO covers. Removal of these can compromise transmission system operation and overall system reliability.
- Tie wrap application and tightness shall conform to Section 14.1.1 of IPC/WHMA-A-620 "Requirements and Acceptance for Cable and Wire Harness Assemblies", January 2002 revision or later. Tie wrap application shall meet the Target and Defect of a Class 3 product per IPC/WHMA-A-620. Use tie wraps on harness covering only, not individual wires. Do not anchor harness with tie wraps in contact with wire insulation. Tie wraps shall not pull on the harness so that connector cable seals are distorted. Allow cable to exit connector body with out pulling on the connector.
- A bend radius of six times the harness diameter is recommended.
- Recommended use of the fixed clip points on OEM harness - Fir trees, J-clips, P-clips.

- Harness routing shall not interfere with oil fill plugs, sensor locations, or manufacturing fixtures.

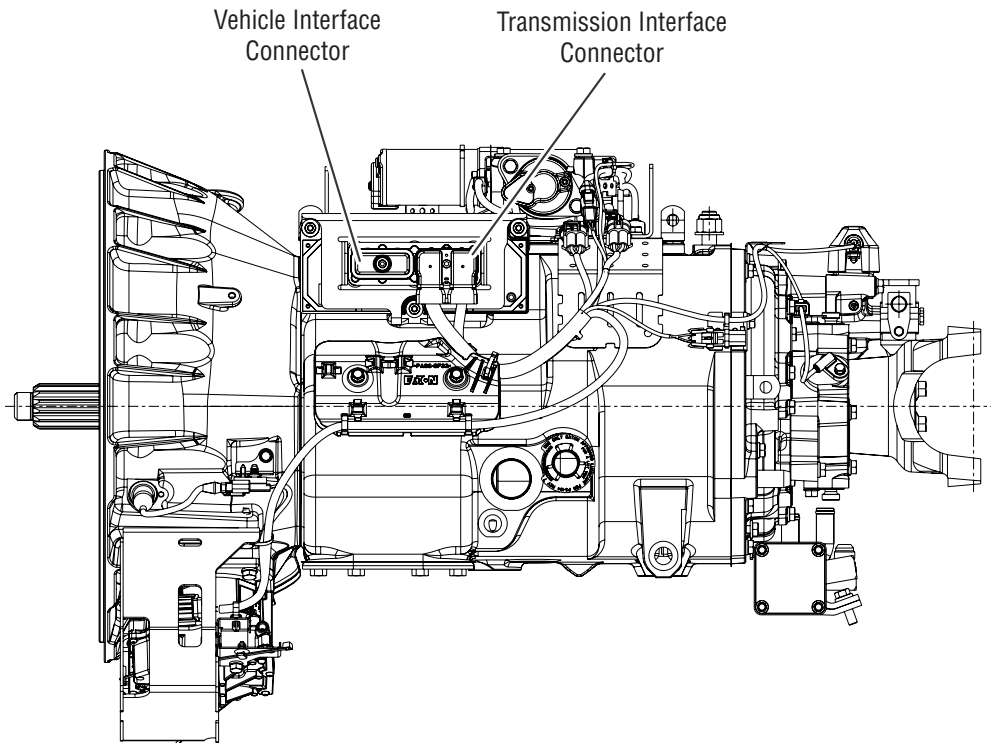

Use for vehicle Harness Tiedown
These are NOT lifting eyes

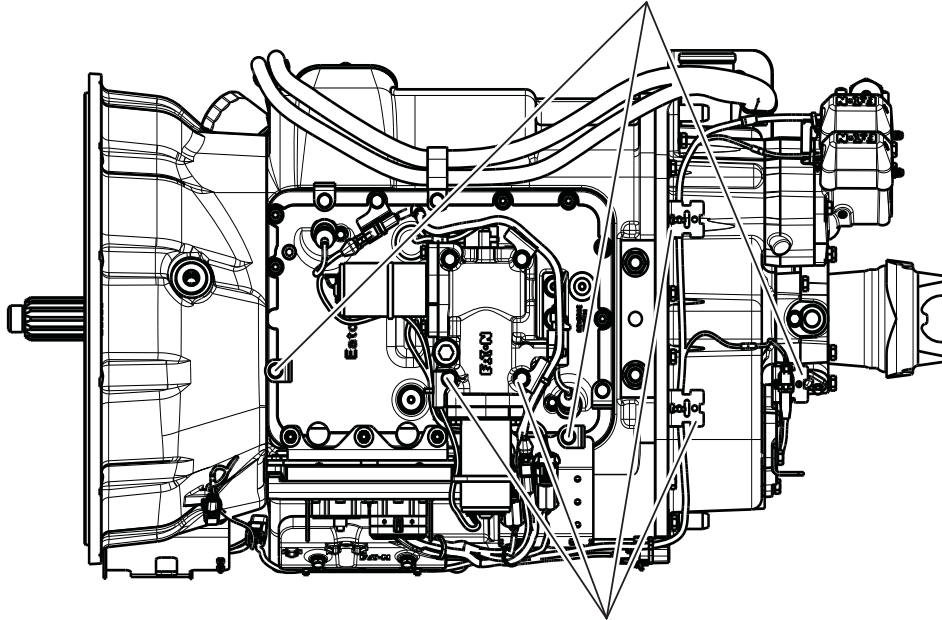

Use for vehicle Harness Tiedown
These are NOT lifting eyes

Use for vehicle Harness Tiedown
These are NOT lifting eyes

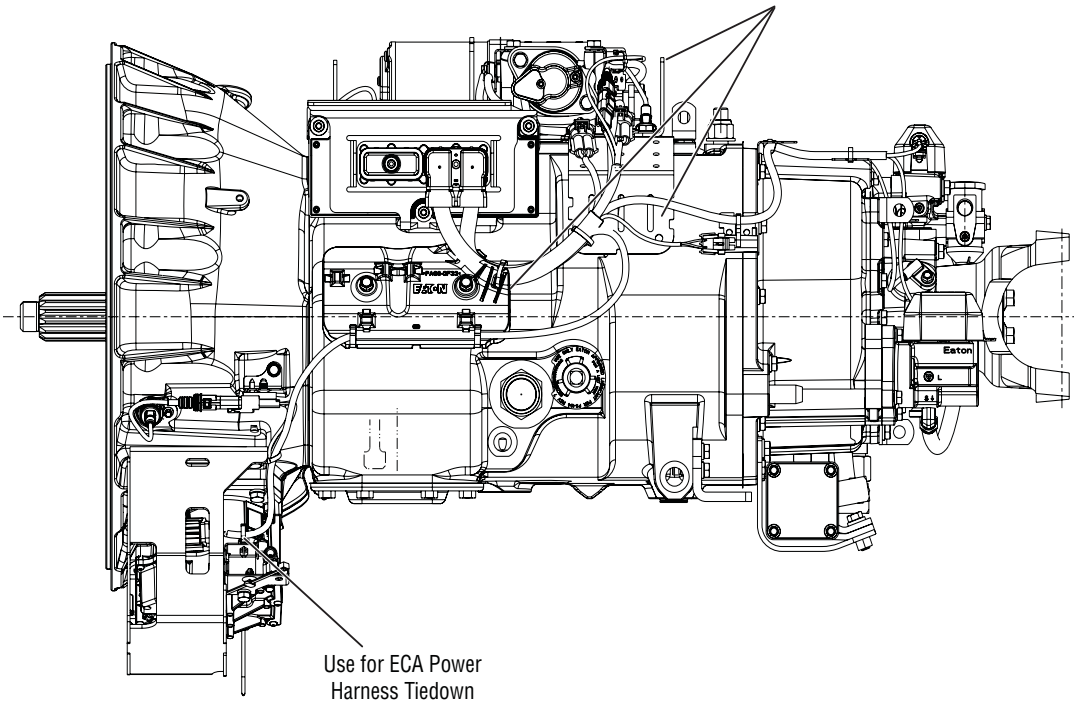

Use for ECA Power
Harness Tiedown

Electrical Wiring Recommendations

Contact Lubrication Recommendation

Note: Eaton recommends the use of (NyoGel 760G) on all electrical contacts. The preferred method of application is to use a metered dispensing mechanism that places the material on the socket of the connector. It is also preferred that the material be placed immediately prior to connector mating to reduce the probability of contamination.

- For further information contact your Eaton OEM Engineering Support Group.
- The NyoGel 760G material shall not be applied to the transmission ECU 38-Way (Vehicle Interface) connector jack-screw. No anti-seize, lubricating, or foreign compound shall be applied to the connector jackscrew threads. The use of such compounds may affect jackscrew torque and prevent proper sealing of the connector.

Harness Design Recommendations

The cable for the Deutsch connector (DRC26-38-S01) should be:

- 18 GXL max /18 TXL min. for Communication and control wires
- 12 GXL or 14 SXL for Power Supply wires
- 12 GXL or 14 SXL for V-Ignition wires

The cable for the 2-Way Deutsch connector should be:

- 10 SXL for Power Supply wires to ECA

The cable for the 8-Way Deutsch connector should be:

- 18 GXL max 18 TXL min. for Communication and control wires to ECA
- 18 GXL for V-Ignition wires

Note: These sizes ensure proper connector sealing and current carrying capacity.

- Splices must be ultrasonically welded per IPC/WHMA-A-620 and encapsulated and sealed to meet SAE-J1455.
- Convuluted Conduit shall have a service temperature of at least 257° F (125° C).
- Braided Loom shall have a service temperature of at least 280° F (138° C). Coverage: A minimum of 10 / maximum of 12 picks per inch. TWISTED CABLES
 - 2 Cables = 10 Twists / 25.4 cm
 - 3 Cables = 8 Twists / 25.4 cm
 - (16 and 18 Gage Cable Only)

SAE Wire	SAE Wire	Nominal Outside Diameter (mm)			Nominal Outside Diameter Inch		
Size mm ²	Size No.	TXL	GXL	SXL	TXL	GXL	SXL
0.8	18	1.98	2.39	2.72	0.08	0.09	0.11
1	16	2.24	2.59	3.05	0.09	0.10	0.12
2	14	2.62	2.97	3.58	0.10	0.12	0.14
3	12	3.25	3.63	4.14	0.13	0.14	0.16
5	10	3.96	4.45	4.95	0.16	0.18	0.20

Cable Connector (Deutsch) - DRC26-38S01-P017

Seal Range (mm) / (in)	Contact Size	Description	Cable Diameter Min (mm ²)	Cable Diameter Max (mm ²)	TXL	GXL	SXL
1.02 - 2.41 / .040 - .095	20	Signal	1.02	2.41	18	18	NR
3.40 - 4.95 / .134 - .195	12	Power	3.40	4.95	NR	12	NR
3.40 - 4.95 / .134 - .195	12	V-Ignition	3.40	4.95	NR	12	14

Cable Connector (Deutsch) - 2-Way DTM06-08SA-E003

Seal Range (mm) / (in)	Contact Size	Description	Cable Diameter Min (mm ²)	Cable Diameter Max (mm ²)	TXL	GXL	SXL
4.40 - 5.15 / .173 - .202	10	Power (ECA)	4.40	5.15	NR	NR	10

Cable Connector Back Shell (Deutsch) - 38-Way DRC series

	Back Shell (Deutsch)	*Low Profile Backshell (Deutsch)
Part Number	0528-004-3805	0528-005-3805
Conduit/OEM	Packard	Packard
Conduit P/N	*(R-69246 round) Con- voluted Tubing; Size 13 mm [.500]; 125° C or higher temperature rating	(R-72506 profile) *(R-69246 round) Con- voluted Tubing; Size 13 mm [.500]; 125° C or higher temperature rating

Electrical Juncture Recommendations

- Do not use more than three (3) ring terminals per mounting stud. Terminals such as ring, bullet, spade, etc., shall be sized for the correct current capacity of the circuit as stated by the manufacturer. Terminals shall be plated and non insulated. Sleeves shall be insulated with a double wall shrink tubing. Sealing Dielectric grease over the top of the ring is recommended.
- Do not use Lock washers or Star washers for contact surfaces.
- Crimps shall be applied with a tool specified by the manufacturer of the terminal and in accordance to the manufacturer's specifications.

Harness Troubleshooting Recommendations and Test Equipment Design

- Removal of fuses is not recommended as the method of disconnecting power from the TCM. Making and breaking a circuit through tin plated terminals (e.g. ring terminals, fuses, and most connectors) will destroy the plating on the terminal. Opening a switch contact or the main power link is the recommended method of interrupting power.
- Harness Probing Damage Alert - Never puncture cable insulation with a probe to verify voltage or to check continuity. Damage to the wire insulation can lead to immediate or future failures of the harness or electronic control unit due to short circuits, water entry, or corrosion.

Note: If a connection to the harness or TCM is required before vehicle installation, Eaton recommends the use of a connector with a spring loaded contact rather than a standard mating connector. The spring loaded contact is intended to make the electrical connection with the tip of the terminal without touching the mating surface. This will protect the terminal plating, the NyoGel 760G™ and retain the original durability and reliability of the connector system.

Power Harness

Transmission ECU Power Harness

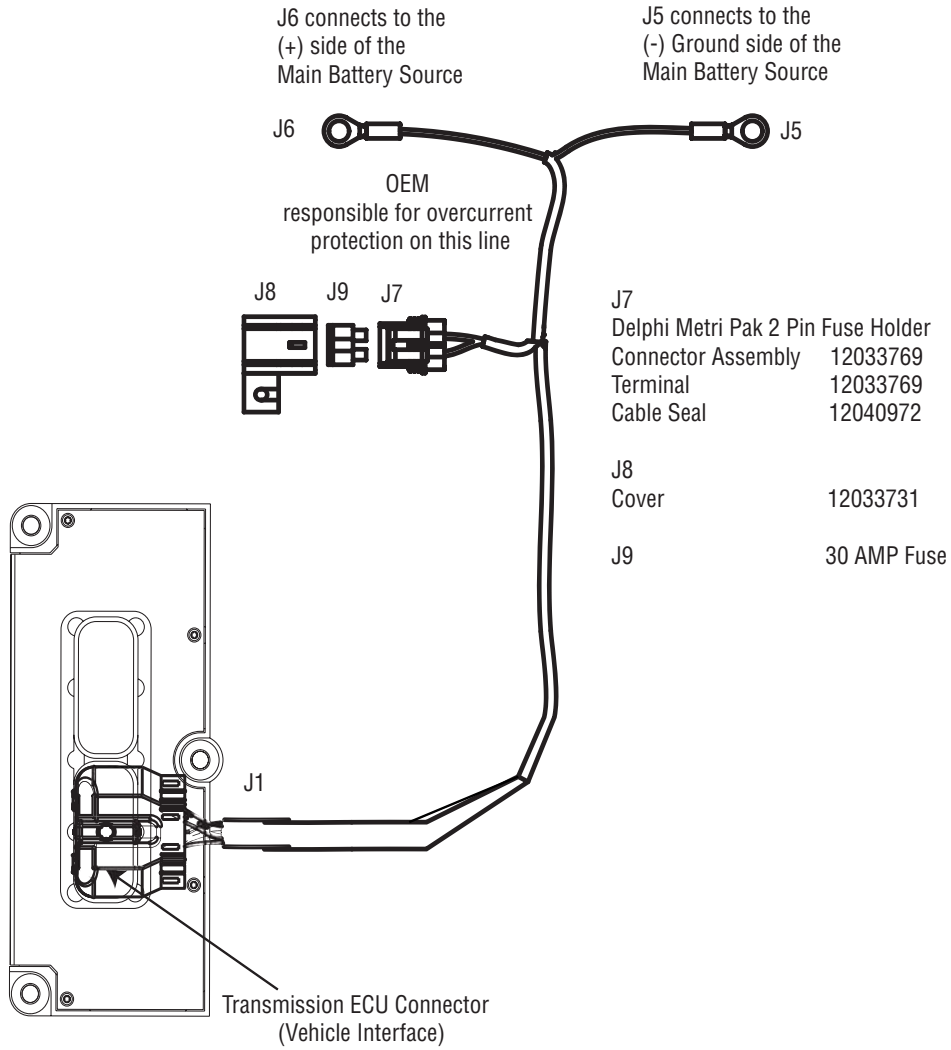

FROM	TO	WIRE DESCRIPTION
J5	J1-36	Battery Negative
J6	J7-B	Battery Positive
J7 A	J1-38	Positive (Fused)

⚠ WARNING

The ECA and ECU battery positive terminations shall be made in accordance to power requirements stated earlier in this section. The termination shall not be made on the battery, frame rail, or starter posts. This applies to battery positive and battery negative.

Electric Clutch Actuator (ECA) Power Harness

J6 connects to the (+) 12 Volt side of the Main Battery Source

J5 connects to the (-) Ground side of the Main Battery Source

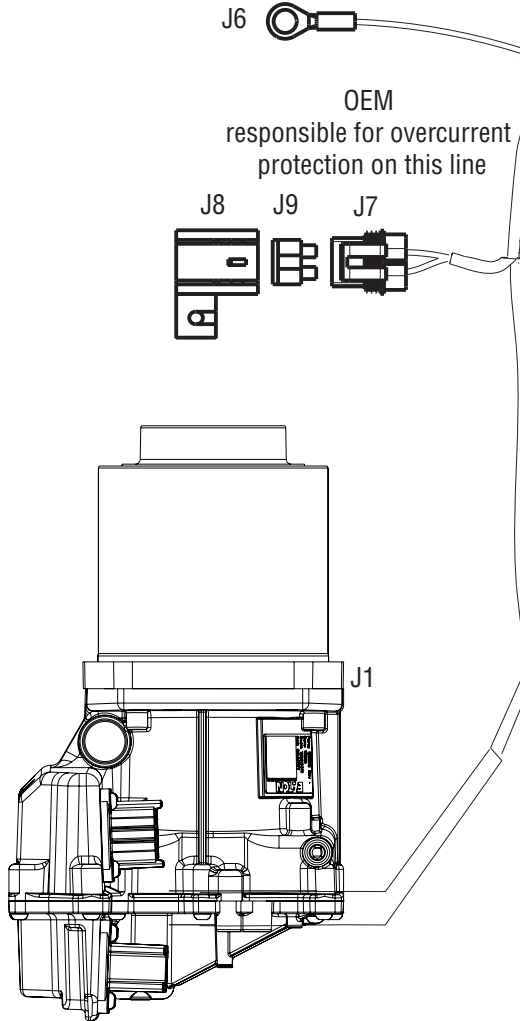

Fuse holder used by Eaton in development Vehicle

50 Amp fuse
LITTLEFUUSE 152 SERIES
Maxi Fuse Splashproof Holder for 20-70 Amp

Part Number Description:

152007Z Cover with Integral seal
1520006Z Body without Mounting Tabs
868-096 Gray Wire Seal for 4-10mm² (10-8AWG)
913-068 Single terminal 4-6mm² (10AWG) Wire

FROM	TO	WIRE DESCRIPTION
J7-A	J1-C (ECA)	Battery Positive (Fused)
J6	J7-B	Battery Positive
J5	J1-B (ECA)	Battery Negative

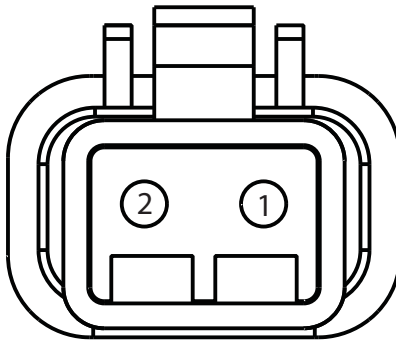

2-WAY ECA CONNECTOR PIN OUT

1	Battery Negative
2	Battery Positive (Fused)

⚠ WARNING

The ECA and ECU battery positive terminations shall be made in accordance to power requirements stated earlier in this section. The termination shall not be made on the battery, frame rail, or starter posts. This applies to battery positive and battery negative.

Typical Electric Clutch Actuator (ECA) Circuit

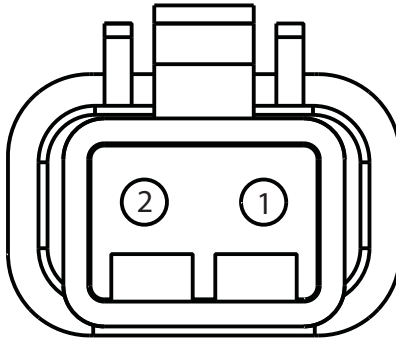
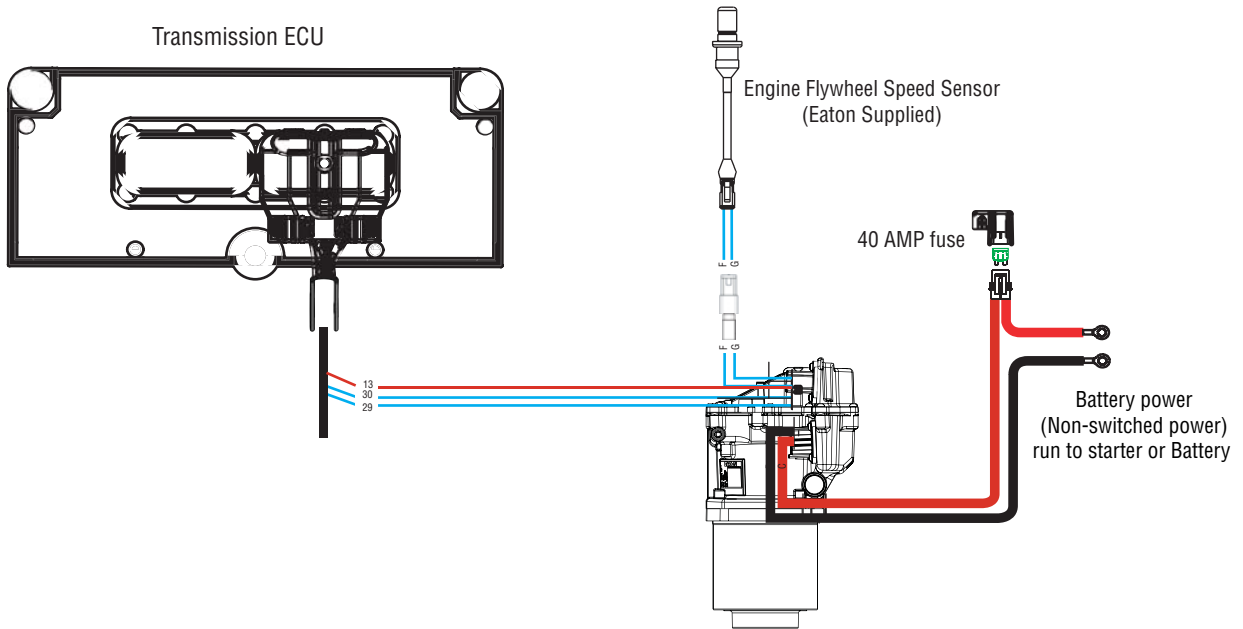

2-WAY ECA CONNECTOR PIN OUT	
1	Battery Negative
2	Battery Positive (Fused)

⚠ WARNING

The ECA and ECU battery positive terminations shall be made in accordance to power requirements stated earlier in this section. The termination shall not be made on the battery, frame rail, or starter posts. This applies to battery positive and battery negative.

Ignition Circuit Detail

Transmission ECU Ignition Circuit

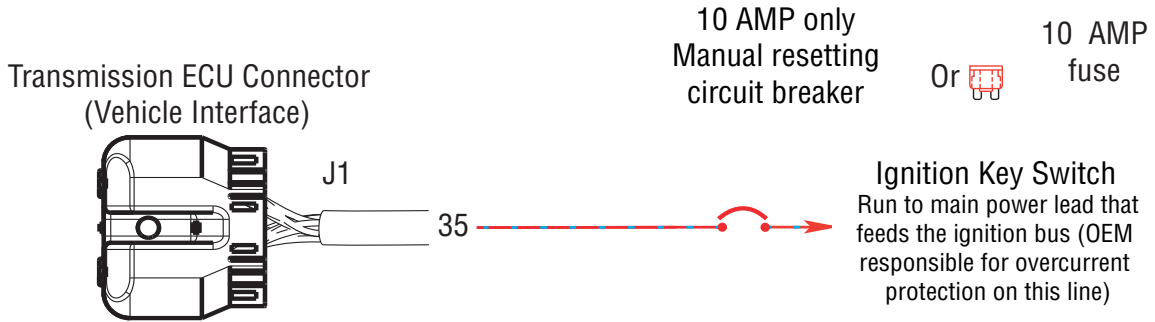

Front View
Transmission ECU Connector
(Vehicle Interface)

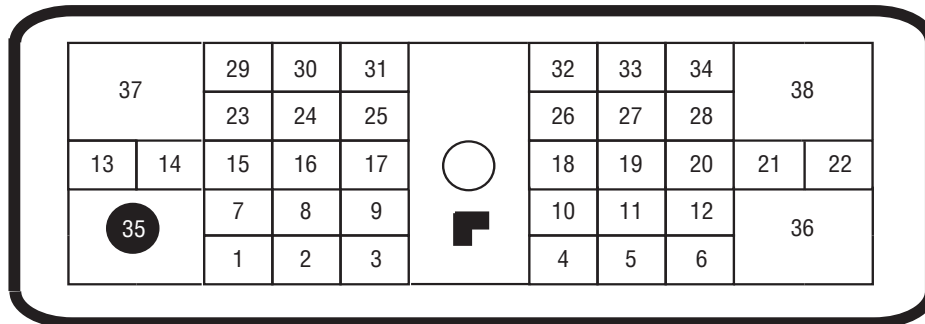

FROM	TO
J1-35	VIGN

Note: Battery and Ignition power and ground to the TECU shall not be switched off during the engine start process.

Typical Start Enable Relay Circuit

Startability shall meet FMVSS Standard 102, Section 3.1.3: “The engine starter shall be inoperative when the transmission shift lever is in a forward or reverse direction position”.

Important: J939 Start Enable Type - The J1939 ETC7 SPN 2900 Transmission Crank Enable message may be used to enable cranking without a relay. A configurable Start Enable Type supports “Relay” or “J1939” control. The J1939 ETC7 SPN 2900 Transmission Crank Enable message may be used to enable cranking without a relay. This feature can be configured with VEPS or Service Ranger 4.

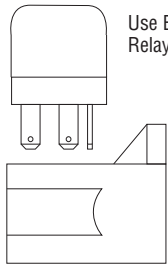

Use Bosch:
Relay : 0332-209-151 (+12 volt), 0332-204-203 (+24 volt) or equivalent

Mount : 3334-485-008
Terminal : 1901-355-917

* Ignition Power (switched power)
Run to main power lead that feeds the ignition bus (OEM responsible for overcurrent protection on this line)

See “Start Enable Relay Requirements” on page 32.

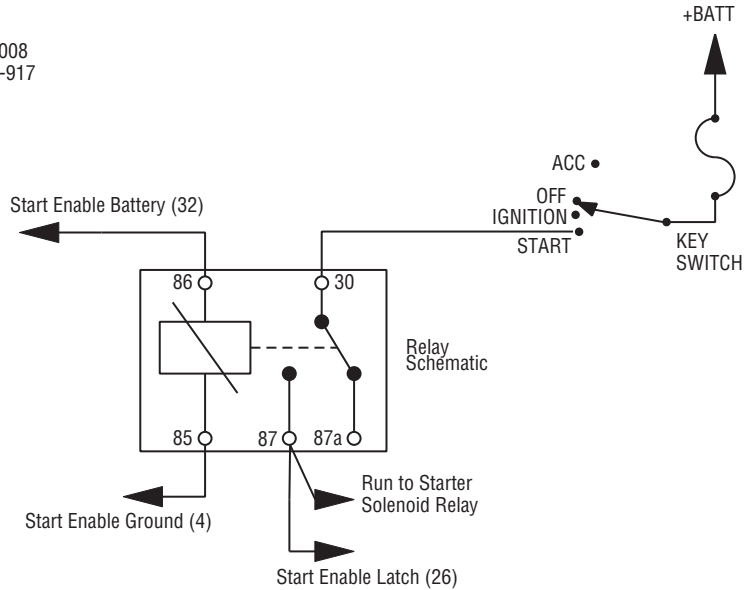

Front View
Transmission ECU Connector
(Vehicle Interface)

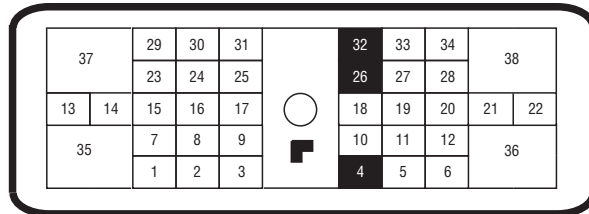

FROM PIN	TO RELAY PIN	DESCRIPTION
J1-32	86	START ENABLE BATTERY
J1-26	87	START ENABLE LATCH
J1-4	85	START ENABLE GROUND

Typical System with Eaton Push Button

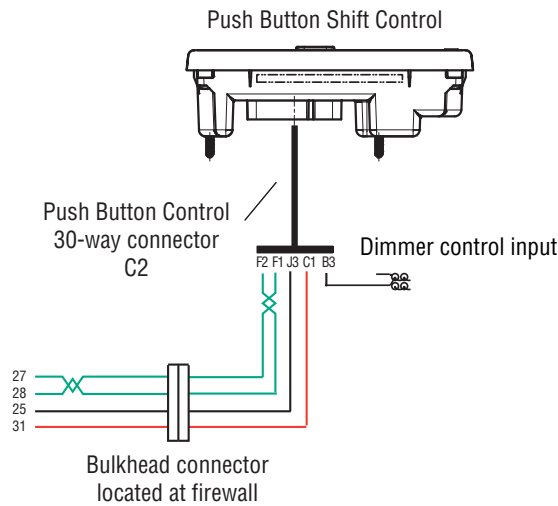

Front View
Transmission ECU Connector
(Vehicle Interface)

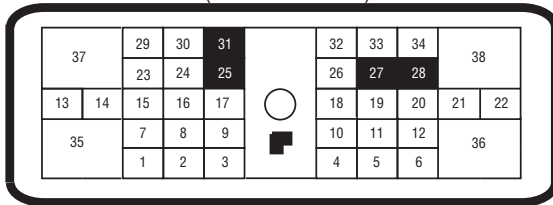

Front View
Shift Control (30-Way Connector)

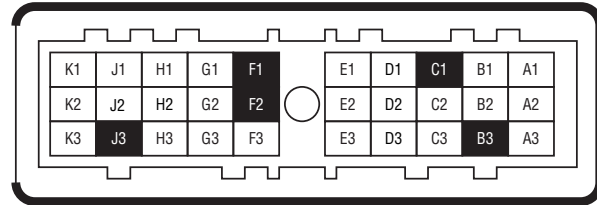

Packard	
Connector	12048455
Terminal	12103881
Plug	12034413

Note: Cinch is an equivalent.

When the Eaton Push Button Shift Control is used the CAN (Control Area Network communications link between the Shift Control and the Transmission Controller) must be a J1939/15 twisted pair cable.

FROM	TO	DESCRIPTION
J1-27	C2-F2	HIL LOW (Proprietary CAN)
J1-28	C2-F1	HIL HIGH (Proprietary CAN)
J1-25	C2-J3	Shift Control Power Minus
J1-31	C2-C1	Shift Control Power Plus
C2-B3		Dimmer Control Input

Typical System with OEM J1939 Shift Input Device

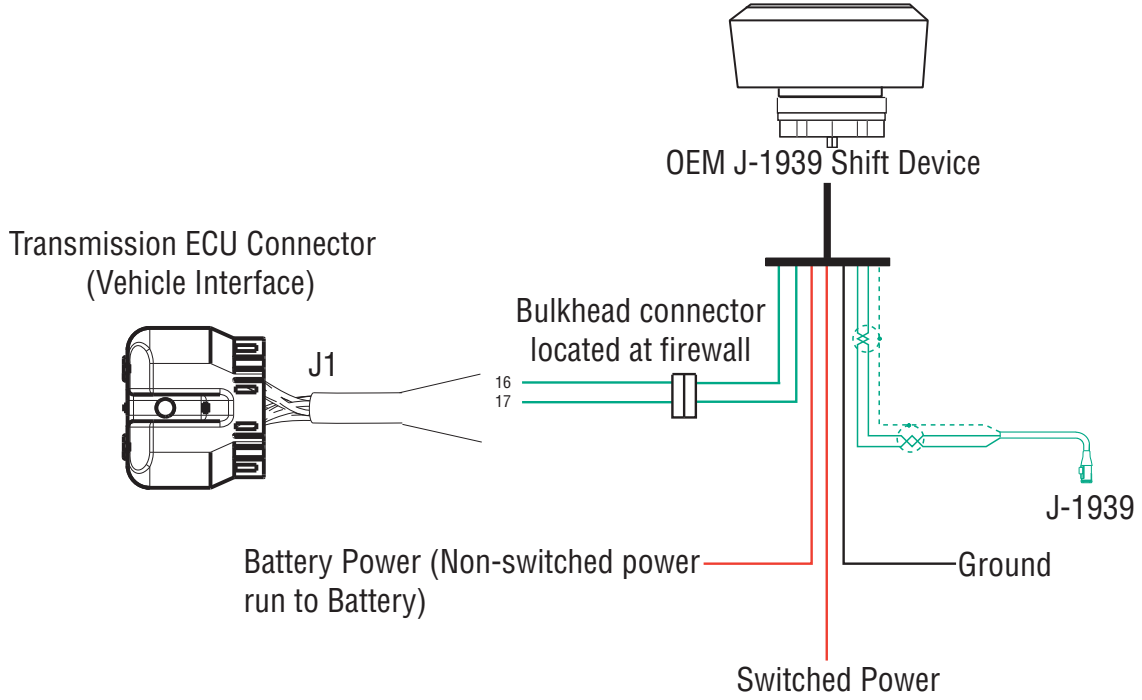

Front View
Transmission ECU Connector
(Vehicle Interface)

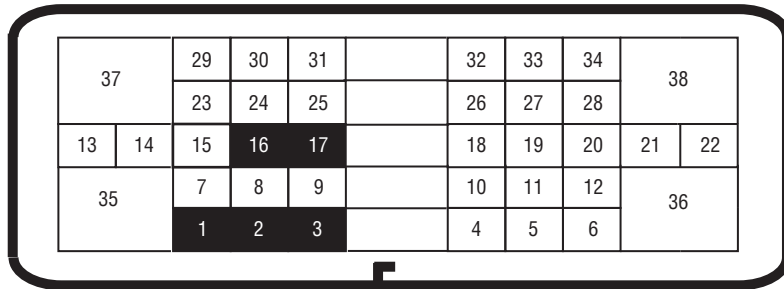

Typical System with OEM Supplied Resistive Ladder Shift Device

OEM supplied Shift Lever shall have gated positions per Eaton engineering specification. If an OEM supplied resistive ladder type shift lever is used in conjunction with a J1939 gear display, Eaton recommends the service lamp connector is located close to the 6 or 9-pin diagnostic connector

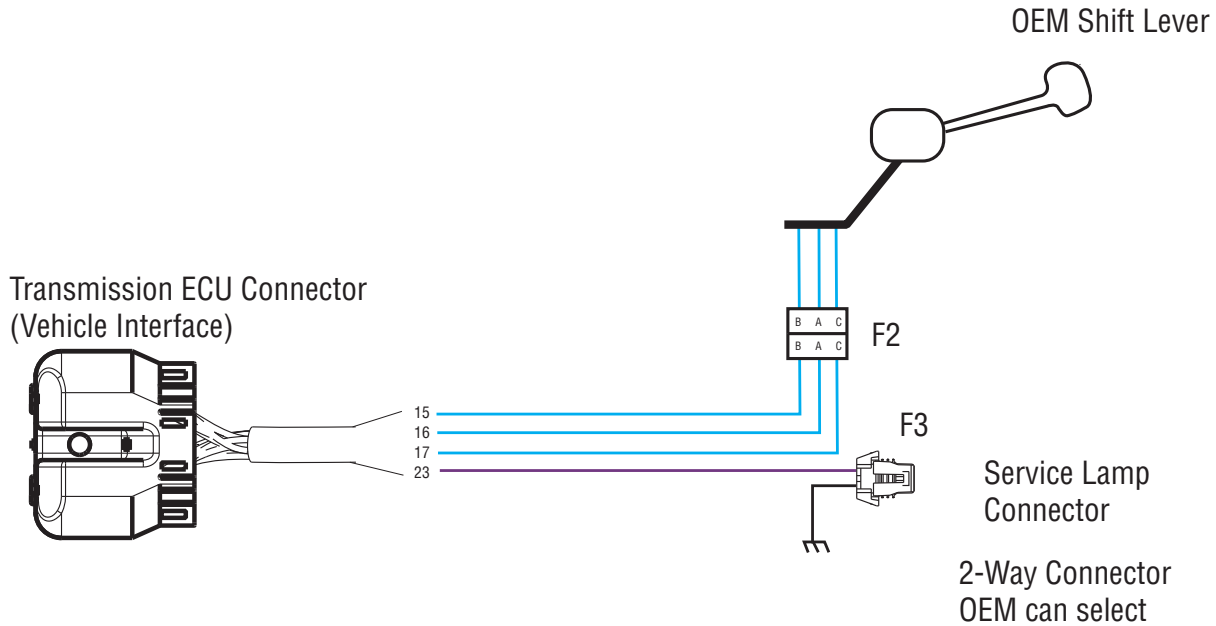

FROM	TO	DESCRIPTION
J1-15	F2-B	Shift Control Input (Mode Auto)
J1-16	F2-A	Shift Control Input (Mode Manual)
J1-17	F2-C	Shift Control Input (Mode Common)
J1-23	F3-A	Service Lamp Output
F3-B		Ground

Typical System with Eaton Shift Lever

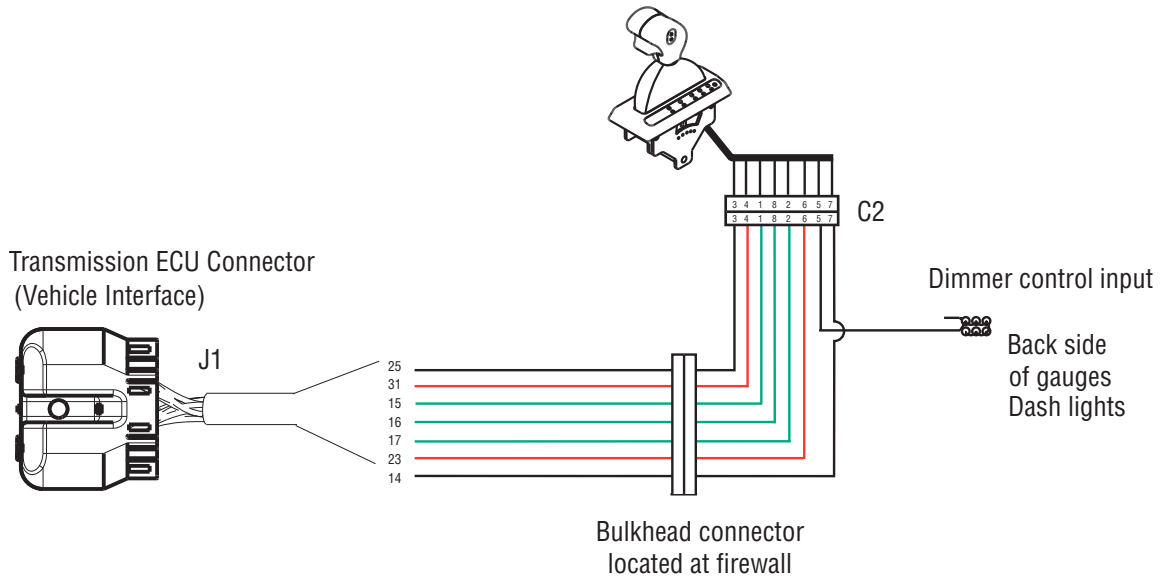

Front View
Transmission ECU Connector
(Vehicle Interface)

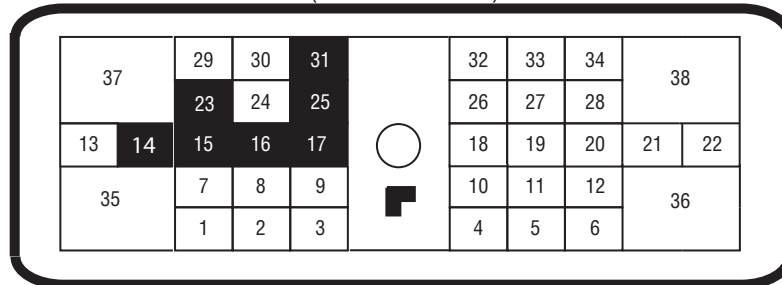

FROM	TO	DESCRIPTION
J1-15	C2-1	Shift Control Input (Mode Auto)
J1-17	C2-2	Shift Control Input (Mode Common)
J1-25	C2-3	Shift Control Power Minus
J1-31	C2-4	Shift Control Power Plus
	C2-5	Dash Lights
J1-23	C2-6	Service Light Output
J1-16	C2-8	Shift Control Input (Mode Manual)
J1-14	C2-7	Shift Control Input (Mode Common 2)

Dimmer Control Input Connection

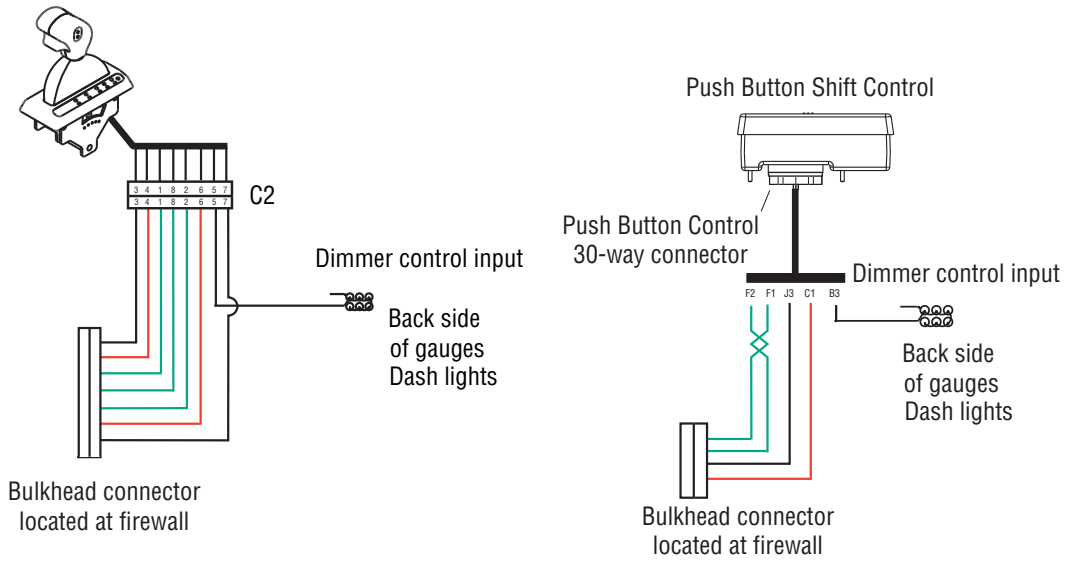

Note: Connect VDASH to the dash lights. This input will dim the lights on the shift device when the lights are on. When VDASH input is off, the lights on the shift device will be on full.

Shift Control	FROM	TO
Cobra Lever	C2-5	VDASH
Push Button	B3	VDASH

Diagnostic Connector

The diagnostic connector (9-pin required) shall be easily accessible and mounted on the drivers side of the cab.

Note: SAE has one approved connector. Eaton requires the Deutsch 9-pin.

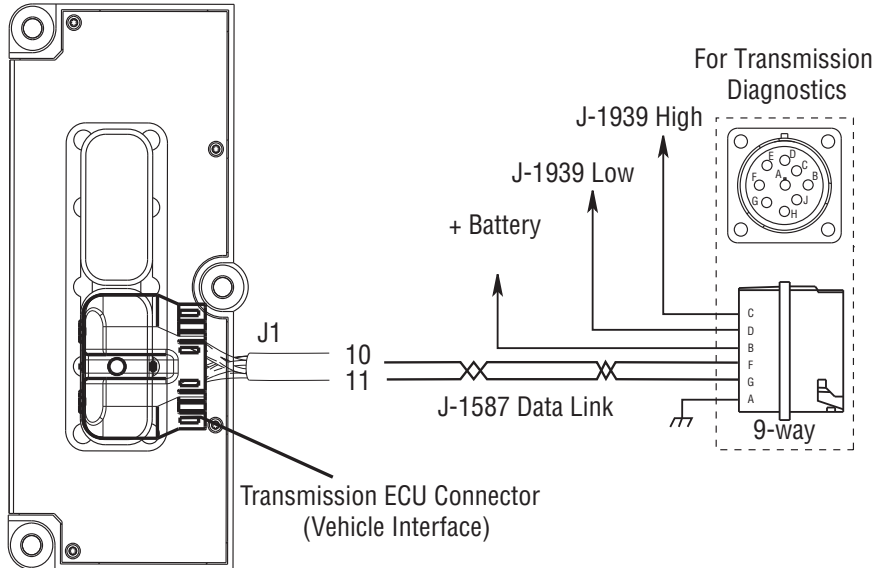

Front View
Transmission ECU Connector
(Vehicle Interface)

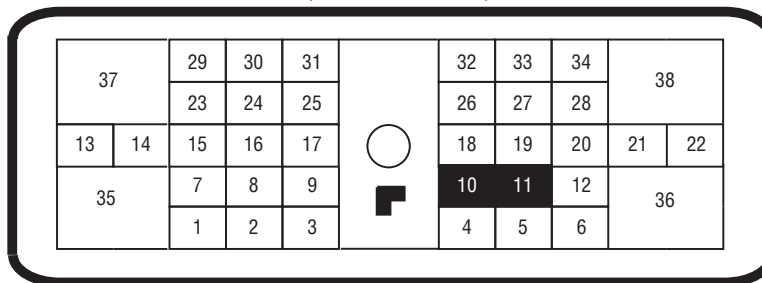

FROM	TO 9-PIN	DESCRIPTION
J1-10	F	J-1587 +
J1-11	G	J-1587 -
—	B	BATTERY +
—	A	GROUND -
—	C	J1939 HIGH
—	D	J1939 LOW

J1939/15 Data Link

The communications link between the Transmission ECU and the Engine Controller ECM shall follow SAE J1939 specifications for either J1939/11 or J1939/15.

- Maximum 40 meter Length.
- Maximum 1 meter stub length.
- Maximum 10 modules on segment.
- Twisted pair (18 gauge) with 1 twist per inch.
- 120 Ohm terminating resistors shall be used.

The third pin for shield is not used with in-line and T-connectors.

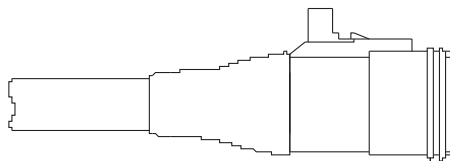
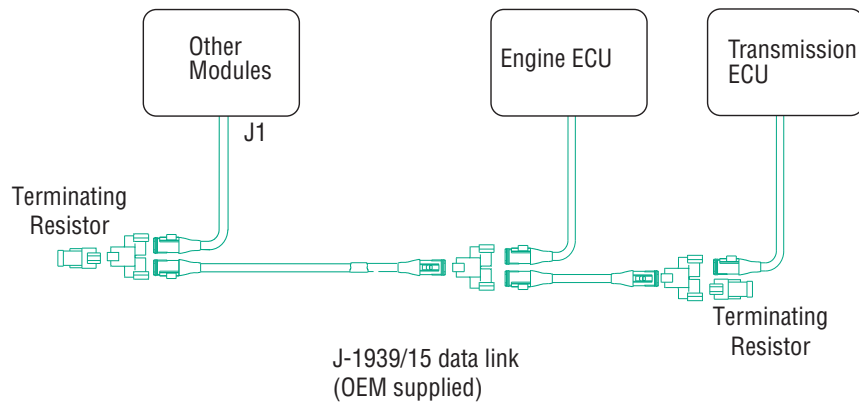

Transmission ECU Connector
(Vehicle Interface)

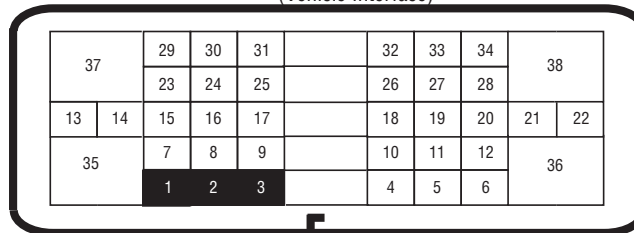

FROM	TO	DESCRIPTION
J1-2	B	J1939 Low
J1-3	A	J1939 High
J1-1	C	J1939 Shield (used only for SAE J1939/11)

Note: The distance between the TECU and Engine ECU should be as short a possible.

J1939/15 Data Link Specifications

Recommended Cable Manufacturer	Cable Part Number	Round	J-1939 (+) (PIN "A") Color	J-1939 (-) (PIN "B") Color
Champlain	J1939/15	Yes	Yellow	Green

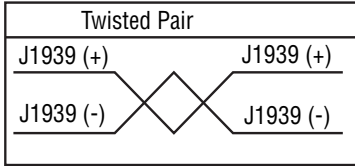

Ref.	Body	Signal Terminals (QTY)	Wedge	Function
A	DTM-06-2S	0462-201-2031 (2)	WM-2S	Through Connector
B	DTM-06-2S	0462-201-2031 (2)	WM-2SB	Stub Connector
C	DTM04-2P-P007	N/A	N/A	"T" Receptacle
D	DTM06-2S-EP10	N/A	WM-2SB	120 Ohm Termination
E	DTM04-2P	0460-202-2031 (2)	WM-2P	ECU Receptacle

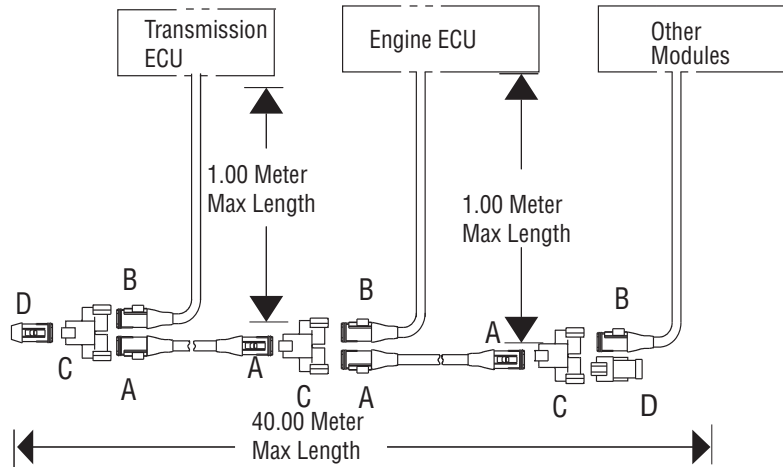

SAE J1939 Data Link Broadcast Messages

Fuller UltraShift *PLUS* models (LAS, LSE, MXP, MHP, VAS, VCS, VHP, VMS and VXP) interface with many different components installed on the vehicle such as engine, shift input device, gear display, and service lamp. SAE J1939 and J1587 data links are standard means to transfer data to other components. Successful system integration is essential to ensure the utmost satisfactory operation of the vehicle. The following sections summarize the system integration requirements.

SPNs listed below are standard on Fuller UltraShift *PLUS* models (LAS, LSE, MXP, MHP, VAS, VCS, VHP, VMS and VXP) Unused data in a PGN is broadcast as “Not Available.” The inability the transmission control unit to broadcast valid data will result in “Error Indicator” or “Not Available” being broadcast. For specific message formatting and broadcast rate see SAE J1939-71 and SAE J1939-73.

Active Diagnostic Trouble Codes (DM1)	PGN 65226
Source Address: 3 (Transmission #1)	
Parameter Name	SPN
Malfunction Indicator Lamp Status	1213
Red Stop Lamp Status	623
Amber Warning Lamp Status	624
Protect Lamp Status	987
Flash Engine Malfunction Indicator Lamp	3038
Flash Engine Red Stop Lamp	3039
Flash Engine Amber Warning Lamp	3040
Flash Engine Protect Lamp	3041
Suspect Parameter Number	1214
FMI	1215
SPN Conversion Method	1706
Occurrence Count	1216

Previously Active Diagnostic Trouble Codes (DM2)	PGN 65226
Source Address: 3 (Transmission # 1)	
Parameter Name	SPN
Malfunction Indicator Lamp Status	1213
Red Stop Lamp Status	623
Amber Warning Lamp Status	624
Protect Lamp Status	987
Flash Engine Malfunction Indicator Lamp	3038
Flash Engine Red Stop Lamp	3039
Flash Engine Amber Warning Lamp	3040
Flash Engine Protect Lamp	3041
Suspect Parameter Number	1214
FMI	1215
SPN Conversion Method	1706
Occurrence Count	1216

Electronic Transmission Controller 1 (ETC1)	PGN 61442
Source Address: 3 (Transmission # 1)	
Parameter Name	SPN
Transmission Driveline Engaged	560
Transmission Shift In Process	574
Transmission Output Shaft Speed	191
Engine Momentary Overspeed Enable	606
Progressive Shift Disable	607
Transmission Input Shaft Speed	161

Electronic Transmission Controller 2 (ETC2)	PGN 61445
Source Address: 3 (Transmission # 1)	
Parameter Name	SPN
Transmission Selected Gear	524
Transmission Actual Gear Ratio	526
Transmission Current Gear	523
Transmission Requested Range	162
Transmission Current Range	163

Electronic Transmission Controller 7 (ETC7)	PGN 65098
Source Address: 3 (Transmission # 1)	
Parameter Name	SPN
Transmission Ready for Brake Release	3086
Transmission Engine Crank Enable	2900
Transmission Requested Gear Feedback	3289
Transmission Warning Indicator	5344
Transmission Mode 1 Indicator	2536
Transmission Mode 3 Indicator	2538

Torque / Speed Control 1 (TSC1) Engine	PGN 0
Source Address: 3 (Transmission # 1)	
Parameter Name	SPN
Engine Override Control Mode	695
Engine Requested Speed Control Conditions	696
Override Control Mode Priority	897
Engine Requested Speed/Speed Limit	898
Engine Requested Torque/Torque Limit	518
Message Counter	4206
Message Checksum	4207

Torque / Speed Control 1 (TSC1) Retarder	PGN 0
Source Address: 3 (Transmission # 1)	
Parameter Name	SPN
Engine Override Control Mode	695
Engine Requested Speed Control Conditions	696
Override Control Mode Priority	897
Engine Requested Torque/Torque Limit	518
Message Counter	4206
Message Checksum	4207

Trans Fluids 2 (TRF2)	PGN 64917
Source Address: 3 (Transmission # 1)	

Broadcast On Request To Transmission

Component Identification (CI)	PGN 65259
Source Address: 3 (Transmission # 1)	
Parameter Name	SPN
Make	586
Model	587
Serial Number	588
Unit Number (Power Unit)	233

Electronic Transmission Controller 3 (ETC3)	PGN 65223
Source Address: 3 (Transmission # 1)	
Parameter Name	SPN
Transmission Shift Finger Gear Position	59
Transmission Shift Finger Rail Position	60
Transmission Shift Finger Rail Actuator 1	772
Transmission Shift Finger Gear Actuator 1	773
Transmission Range High Actuator	768
Transmission Range Low Actuator	769
Transmission Splitter Direct Actuator	770
Transmission Splitter Indirect Actuator	771
Transmission Inertia Brake Actuator	787

Electronic Transmission Controller 4 (ETC4)	PGN 65221
Source Address: 3 (Transmission # 1)	
Parameter Name	SPN
Transmission Synchronizer Brake Value	54

Software Identification (SOFT)	PGN 65242
Source Address: 3 (Transmission # 1)	
Parameter Name	SPN
Number of Software Identification Fields 965	965
Software Identification 234	234

ECU Identification Information (ECUID)	PGN 64965
Source Address: 3 (Transmission # 1)	
Parameter Name	SPN
ECU Part Number	2901
ECU Serial Number	2902
ECU Location	2903
ECU Type	2904
ECU Manufacturer Name	4304

Vehicle Electrical Power 1 (VEP1)	PGN 65271
Source Address: 3 (Transmission # 1)	
Parameter Name	SPN
Battery Potential / Power Input 1 168	168
Key switch Battery Potential 158	158

SAE J1939 Data Link Received Messages

Fuller UltraShift *PLUS* models (LAS, LSE, MXP, MHP, VAS, VCS, VHP, VMS and VXP) interface with many different components installed on the vehicle such as engine, shift input device, gear display, and service lamp. SAE J1939 and J1587 data links are standard means to transfer data to other components. Successful system integration is essential to ensure the utmost satisfactory operation of the vehicle. The following sections summarize the system integration requirements.

For specific message formatting and broadcast rate see SAE J1939-71 and SAE J1939-73.

Cruise Control / Vehicle Speed (CCVS)	PGN 65265
Source Address: 49 (Cab Controller - Primary), 0 (Engine #1), 17 (Cruise Control), 23 (Instrument Cluster #1), 33 (Body Controller), 39 (Management Computer) Note: For each signal in the CCVS message, the first Source address that is supported and has valid data is latched for the power cycle. Address then that sending Brake Switch data.	
Parameter Name	SPN
Parking Brake Switch	70
Wheel-Based Vehicle Speed	84
Brake Switch	597

Component Identification (CI)	PGN 65259
Source Address: 5 (Shift Console – Primary) Note: The accepted CI shall be defined as Model type “RNDML”. “RNDML” shall be the first Model characters received by the requester. Additional Model information shall be separated by a dash (RNDML-XXXX).	
Parameter Name	SPN
Make	586
Model	587
Serial Number	588
Unit Number (Power Unit)	233

STOP START BROADCAST (DM13)	PGN 57088
Source Address: Global	
Parameter Name	SPN
Current Data Link	1230

Electronic Brake Controller 1 (EBC1)	PGN 61441
Source Address: 11 (Brakes - System Controller)	
Parameter Name	SPN
Brake Pedal Position	521
ASR Engine Control Active	561
ASR Brake Control Active	562
Anti-Lock Braking (ABS) Active	563
ABS Off-Road Switch	575
ASR Off-Road Switch	576
ASR "Hill Holder" Switch	577
Engine Retarder Selection Additional Source Addresses: 00 (Engine #1) 17 (Cruise Control) 49 (Cab Controller)	973

Electronic Brake Controller 5 (EBC5)	PGN 64964
Source Address: 11 (Brakes - System Controller)	
Parameter Name	SPN
Hill Holder Mode	2912

Engine Configuration 1 (EC1)	PGN 65251
Source Address: 0 (Engine #1)	
Parameter Name	SPN
Engine Speed At Idle, Point 1	188
Engine Percent Torque At Idle, Point 1	539
Engine Speed At Point 2	528
Engine Percent Torque At Point 2	540
Engine Speed At Point 3	529
Engine Percent Torque At Point 3	541
Engine Speed At Point 4	530
Engine Percent Torque At Point 4	542
Engine Speed At Point 5	531
Engine Percent Torque At Point 5	543
Engine Speed At High Idle, Point 6	532
Engine Reference Torque	544
Engine Maximum Momentary Override Speed, Point 7	533

Electronic Engine Controller 1 (EEC1)	PGN 61444
Source Address: 0 (Engine #1)	
Parameter Name	SPN
Engine Torque Mode	899
Driver's Demand Engine - Percent Torque	512
Actual Speed - Percent Torque	513
Engine Speed	190

Electronic Engine Controller 2 (EEC2)	PGN 61443
Source Address: 49 (Cab Controller - Primary), 0 (Engine #1), 17 (Cruise Control), 23 (Instrument Cluster #1), 33 (Body Controller)	
Parameter Name	SPN
Accelerator Pedal Position 1	91
Estimated Pumping - Percent Torque	5398

Electronic Engine Controller 3 (EEC3)	PGN 65247
Source Address: 0 (Engine #1)	
Parameter Name	SPN
Nominal Friction - Percent Torque	514
Engine's Desired Operating Speed	515
Engine's Desired Operating Speed Asymmetry Adjustment	519
Estimated Engine Parasitic Losses - Percent Torque	2978

Electronic Retarder Controller 1 (ERC1)	PGN 61440
Source Address: 15 (Retarder – Engine), 41 (Retarder, Exhaust, Engine #1)	
Parameter Name	SPN
Retarder Enable - Brake Assist Switch	571
Actual Retarder - Percent Torque	520

PTO Drive Engagement (PTODE)	PGN 64932
Source Address: For the output shaft PTO engagement status SPN, the first source address that has valid data is latched.	
Parameter Name	SPN
Output Shaft PTO Engagement Status	3462

Engine Temperature 1 (ET1)	PGN 65262
Source Address: 0 (Engine #1)	
Parameter Name	SPN
Engine Coolant Temperature	110

Retarder Configuration (RC)	PGN 65249
Source Address: 15 (Retarder – Engine), 41 (Retarder, Exhaust, Engine #1)	
Parameter Name	SPN
Reference Retarder Torque	556

Transmission Control 1 (TC1)	PGN 256
Source Address: 5 (Shift Console - Primary) Interfacing with J1939 Driver Input Device requires TC1.	
Parameter Name	SPN
Transmission Requested Gear	525

Transmission Control 1 (TC1)	PGN 256
Source Address: For the output shaft PTO engagement status SPN, the first source address that has valid data is latched.	
Parameter Name	SPN
Transmission Mode 3 Request	1854
Transmission Requested Gear	525
Transmission Requested Clutch Slip	684

Transmission Control 1 (TC1)	PGN 256
Source Address: 0 (Engine # 1) Neutral Coast requires engine support of TC1 , unless an alternate message has been explicitly communicated for specific vehicle configurations.	
Parameter Name	SPN
Transmission Mode 1	1852
Disengage Driveline Request	684

Shutdown (SHUTDN)	PGN 65252
Source Address: 0 (Engine #1)	
Parameter Name	SPN
Engine Protection System has Shutdown Engine	1110
Engine Protection System Approaching Shutdown	1109

Vehicle Distance (VD)	PGN 65248
Source Address: Global	
Parameter Name	SPN
Total Vehicle Distance	245

Received On Request From Transmission

Time / Date (TD)	PGN 65254
Source Address: Global	
Parameter Name	SPN
Seconds	959
Minutes	960
Hours	961
Month	963
Day	962
Year	964
Local minute offset	1601
Local hour offset	1602

SAE J1587 Data Link Broadcast Messages

Note: All messaging protocol shown on this page are new to this product family.

Note: Unused data in a PID is broadcast as “Not Available.” Reference SAE J1587 for complete specification.

Broadcast Period	Parameter Name	PID
100 ms	Transmission Output Shaft Speed	191
400 ms	Text Message to Display Note: PID 226 controls the tone. Cadence of the tone is controlled by Gen 3.	226
500 ms	Transmission Range Selected	162
	Transmission Range Attained	163
1.0 s	Battery Potential (Voltage)	168
Upon change or 15 s while fault active	Transmitter System Diagnostic Code and Occurrence Count Table	194
On Request	Clutch Cylinder Position	33
	Transmission Synchronizer Brake Value	54
	Transmission Actuator Status #2	57
	Shift Finger Actuator Status	58
	Shift Finger Gear Position	59
	Shift Finger Rail Position	60
	Transmission Actuator Status #1	63
	Vehicle Enabling Component Status	66
	Shift Request Shift Status	67
	Battery Potential (Voltage) - Switched	158
	Transmission Main Shaft Speed	160
	Transmission Input Shaft Speed	161
	Engine Speed	190
	Multi-Section Parameter	192
	Diagnostic Data Request/Clear Count	195
	Diagnostic Data/Count Clear Response	196
	Software Identification	234
	Component Identification Parameter	243
Total Vehicle Hours	246	

Gear Display

The OEM is responsible for supplying the gear display, wiring, and its location per FMVSS.

Gear display is required for proper operation of Fuller UltraShift *PLUS* models (LAS, LSE, MXP, MHP, VAS, VCS, VHP, VMS and VXP) Gear Display shall interface with any Eaton product by either SAE J1939 (ETC2) or J1587 (PID 226). The gear display offers real-time information pertaining to current engaged gear, engagement status during gear shifting, transmission synchronization during shifting, transmission fault status, diagnostic code information.

Gear display shall adhere to the following requirements.

- As a minimum, gear display shall support two character alphanumeric messages with the addition of two sets of display arrows (up and down) either side of the numerals.
- As a minimum, gear display shall be able to display all two character numeric combinations and alphanumeric combinations listed in the following table. It is preferred that the gear display support all uppercase letters to support product enhancements.
- For J1587, display time of a message shall be set to 5 seconds to avoid display blanking during heavy bus loads.
- Driver shall be able to clearly see the display from the normal driving position continuously during vehicle operation.
- Gear Display shall be capable of displaying messages within 2 seconds of ignition key-on.
- In order to provide real-time feedback of the selection/shifting/engagement process of transmission, the device shall be able to display the received message within 75 Milliseconds.
- Whenever bus communications are active and anytime ETC2/PID 226 message is not received within 5 seconds of the last valid message or message received contains a character not supported, the display shall be blank.
- Whenever bus communications are not active, a “ ** ” shall be displayed.

Note that the alphanumeric character in byte 7 is to be displayed to the left of the alphanumeric character in byte 8. If only one character is required, then byte 7 shall contain an ASCII space. Byte 8 shall contain the single character.

Defined Control Characters

When a control action is sent, the display characters shall not change. For example, if a ‘4’ was shown prior to an arrow being displayed, then a ‘4’ will remain on the display while the request for an arrow is given.

Control Type	Byte 7	Byte 8	Bits	8	7	6	5	4	3	2	1
Up / Down Arrow	0x00	No Arrow		-	-	-	-	-	-	0	0
		Up Arrow		-	-	-	-	-	-	0	1
		Down Arrow		-	-	-	-	-	-	1	0
		Up Arrow & Down Arrow		-	-	-	-	-	-	1	1
Tone (Cadence controlled by Generation 3)	0x00	Tone Off		-	-	-	-	0	0	-	-
		Tone On		-	-	-	-	0	1	-	-
		Undefined		-	-	-	-	1	0	-	-
		Undefined		-	-	-	-	1	1	-	-
Reserved	0x00	Default Unused State		1	1	1	1	-	-	-	

Minimum Gear Display Alphanumeric Combinations

Display	First Character (dec./hex/char)	Second Character (dec./hex/ char)	Comments
R4	82 / 52 / "R"	52 / 34 / "4"	"R" = "reverse"
R3	82 / 52 / "R"	51 / 33 / "3"	"R" = "reverse"
R2	82 / 52 / "R"	50 / 32 / "2"	"R" = "reverse"
R1	82 / 52 / "R"	49 / 31 / "1"	"R" = "reverse"
N	32 / 20 / " "	78 / 4E / "N"	"N" = "neutral"
1	32 / 20 / " "	49 / 31 / "1"	
2	32 / 20 / " "	50 / 32 / "2"	
3	32 / 20 / " "	51 / 33 / "3"	
4	32 / 20 / " "	52 / 34 / "4"	
5	32 / 20 / " "	53 / 35 / "5"	
6	32 / 20 / " "	54 / 36 / "6"	
7	32 / 20 / " "	55 / 37 / "7"	
8	32 / 20 / " "	56 / 38 / "8"	
9	32 / 20 / " "	57 / 39 / "9"	
10	49 / 31 / "1"	48 / 30 / "0"	
11	49 / 31 / "1"	49 / 31 / "1"	
12	49 / 31 / "1"	50 / 32 / "2"	
13	49 / 31 / "1"	51 / 33 / "3"	
14	49 / 31 / "1"	52 / 34 / "4"	
15	49 / 31 / "1"	53 / 35 / "5"	
16	49 / 31 / "1"	54 / 36 / "6"	
17	49 / 31 / "1"	55 / 37 / "7"	
18	49 / 31 / "1"	56 / 38 / "8"	
F	32 / 20 / " "	70 / 46 / "F"	"F" = "fault"
CA	67 / 43 / "C"	65 / 41 / "A"	"CA" = "clutch abuse"
L	32 / 20 / " "	76 / 4C / "L"	"L" = "low gear"
ST	83 / 53 / "S"	84 / 54 / "T"	"ST" = "snap shot"
PD	80 / 50 / "P"	68 / 44 / "D"	"PD" = "product diagnostic"
-	32 / 20 / " "	45 / 2D / "-"	
GI	71/47/ "G"	73/49/ "I"	"GI" = "grease interval"
PS	80/50/ "P"	85/83/ "S"	"PS" = "product service"

Hill Start Aid

This product is designed to work seamlessly in conjunction with a Hill Start Aid equipped brake system. The Hill Start Aid system prevents unwanted vehicle movement on steep grades when transitioning from the brake pedal to the throttle pedal. When Hill Start Aid is activated, the system applies the foundation brakes for up to 3 seconds during operator brake-to-throttle transitions while the vehicle is operating forward or reverse, in either a 3% or greater grade (either incline or decline).

Note: Refer to TRAG2600 for the latest information on Tridem axle configuration approvals.

- The OEM is required to install a Hill Start Aid system in the vehicle. This includes the addition of brake system valves and unique ABS controllers required by the brake manufacturer.
- This product is compatible with Wabco and Bendix brake systems. Contact the brake manufacturer to ensure the correct level of ABS ECU software and hardware is specified.

HSA

- A minimum of 4 Channel (4S/4M) Traction control (ATC) system compatible with UltraShift® *PLUS* Hill Start Aid (HSA) is required. Other traction control configurations greater than 4S/4M are approved.
- HSA & ATC compatible with UltraShift® *PLUS* are required on export vehicles where ABS is mandated by local law and optional on vehicle configurations where ABS is not mandated by local law.

Hill Start Aid Switch Requirements

- The Hill Start Aid requires an operator accessible on/off override momentary control switch.
- The OEM is responsible for supplying the on/off control switch. Contact the brake manufacturer for Hill Start Aid system and switch requirements.
- The switch shall default to “On” unless changed by the operator.
- While in default “On” mode:
 - The switch can be turned “Off” by pressing and releasing the Hill Start Aid Switch.
 - The System will default to “On” after the first successful launch.
 - If the switch is turned “Off”, the lamp will flash (Refer to operator manual).

Hill Start Aid Lamp Requirements

- The OEM is responsible for providing a lamp to communicate system status messages of the “Hill Holder” switch. It is recommended that the light be amber in color.
- The in cab lamp shall communicate system status as follows:
 - In Cab Lamp Comm HSA System ON - The lamp will be off during normal operation of Hill Start Aid.
 - HSA System OFF - The system will flash the lamp when the system is disabled.
 - HSA System Fault - The lamp shall be solid on for any faults that affect the HSA function.
 - Lamp Failure - It shall be the responsibility of the operator to verify start up bulb check.

Note: The OEM is responsible for identification of the switch and light, in accordance with Brake Manufacturer's recommendations.

Auto Neutral

Starting with the release of software # 5569892 it will be acceptable to use a J1939 Park brake signal in place of the switch. Refer to the table in the section SAE J1939 Data Link Received Messages. An auto neutral feature is provided with this transmission which forces the transmission into neutral in all instances when the parking brake is applied. This requires the OEM to “T” a normally closed pressure switch into the existing air line to the parking brake valve. Contact the brake manufacturer for pressure switch requirements. The pressure switch output and return wires are connected to the vehicle interface transmission ECU connector as follows:

Description	From	To
Auto Neutral Signal	Pin 19	Signal Wire
Auto Neutral Return	Pin 33	Return Wire

Automatic Traction Control (ATC)

This product requires a minimum 4 channel (4S/4M) traction control system for a tandem drive axle or single drive axle. Refer to TRAG2600 for tridem axle configuration approvals.

Shift Input Device

UltraShift *PLUS* transmissions will work with analog, PNL or J1939 shift input devices.

Contact Eaton OEM engineering representative for shift input device design and interface requirements.

Engine

Engine Configuration - The engine ECU shall contain the proper configuration settings. For the proper engine configuration settings required for Eaton Automated Transmission operation refer to TRIG0910, the “Engine Configuration Settings Installation Guide” on roadranger.com under the literature center.

Fan Drive Requirements - The required practice is for the engine fan to be wired into the engine ECM, this includes the manual fan override switch. The OEM should use fan clutches that can be controlled by the engine (i.e. electromechanical). Failure to comply with this recommended practice can cause Eaton transmissions to inhibit shifts when the engine fan is on.

Contact Eaton OEM Engineering representative for engine interface requirements.

Remote Throttle Enable

The transmission system provides a remote throttle enable output, ECU pin V24, for use with PTO's to control an interlock relay or similar device supplied by the OEM or body builder. This output is 12 volts in the enabled state and 0 volts or open in the disabled state. Output functionality is configurable, i.e. ON/OFF, using an Eaton service tool such as ServiceRanger.

System Function

The system shall prevent remote throttle operation while the transmission is in gear or moving. Therefore the following conditions are required for enabling the output:

- The Remote Throttle Enable shall be configured ON
- The vehicle park brake has been applied.
- Transmission in Neutral
- Vehicle is stationary

There are possible system faults which could disable this function.

Auxiliary Transmissions

UltraShift *PLUS* Functional Compatibility with an AT-1202 Auxiliary Transmission

- Shift the AT-1202 only when stopped. Refer to Eaton bulletin TAIB0815.
- Only an air shifted AT-1202 is compatible with Eaton automated transmissions, manually shifted AT-1202 is not compatible.
- UltraShift *PLUS* is compatible only with the Eaton AT-1202. Other driveline auxiliary transmissions are not compatible at this time.
- UltraShift *PLUS* requires the AT-1202 ratio state for proper shift point selection and gear synchronization of the transmission during shifting.
- Vehicle speed sensor needs to be mounted on the output of the AT-1202 to reflect correct vehicle speed.
- Inputs: A normally open switch is required to indicate that the AT-1202 is in Direct or Reduction. This switch needs to be plumbed into the Auxiliary Transmission High/Direct air line. For proper determination of Auxiliary Transmission ratio state UltraShift *PLUS* Transmission Electronic Control Unit pins V12 (signal) and V13 (return) must be detected as follows:

Auxiliary transmission shift state	Air pressure at High/Direct port	Air Pressure switch state	
High/Direct	Air pressure present	Closed	Switch state closed. The signal from V12 now is able to return to the TECU on V13
Low/Reduction	No air pressure	Open	Switch state open. The signal from V12 cannot return to the TECU on V13
Neutral	No air pressure	Open	Switch state open. The signal from V12 cannot return to the TECU on V13

- Configuration: the default ServiceRanger configuration is “Auxiliary Transmission Not Installed”. Use Eaton ServiceRanger to change the configuration to “Eaton AT-1202”. UltraShift *PLUS* automatically determines if the AT-1202 is in Reduction or Direct when properly configured.
- The red line designates the High/Direct line that the normally open switch needs to be plumbed into.

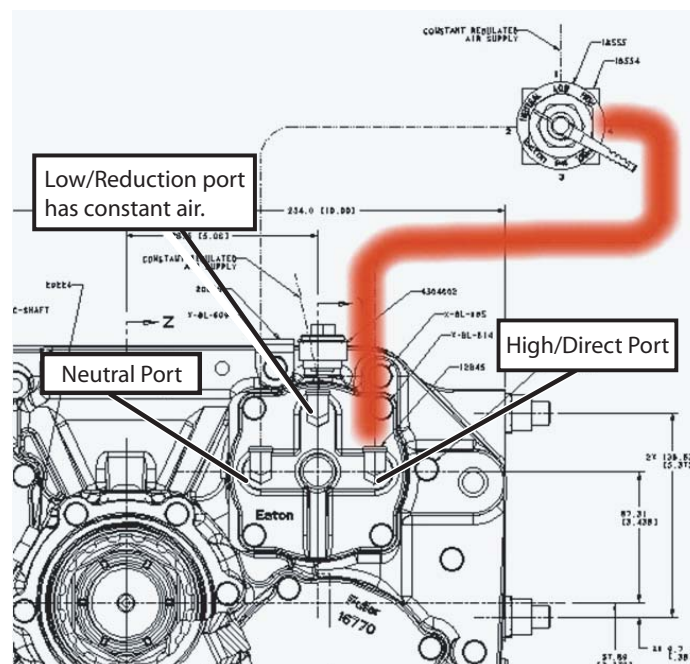

Alert Tone

The OEM is responsible for supplying the tone module with the Eaton Shift Lever or OEM Driver Interface Device. The tone module is supplied in the Eaton push button shift control.

Alert tone shall be required for proper operation of Fuller UltraShift *PLUS* models (LAS, LSE, MXP, MHP, VAS, VCS, VHP, VMS and VXP) The alert tone shall be used to:

- Inform the operator that the transmission has not yet confirmed a neutral request.
- Inform the operator that an invalid/improper request or operation was initiated.
- Implement the shift prompt for AutoSelect fallback mode.
- Warn of a clutch abuse situation.

The required tone information shall be conveyed from Fuller UltraShift *PLUS* models (LAS, LSE, MXP, MHP, VAS, VCS, VHP, VMS and VXP) via SAE J1939 (ETC2) and J1587 (PID 226).

Alert tone shall adhere to the following requirements.

- Driver shall be able to clearly hear the tone from the normal driving position continuously during vehicle operation.
- Alert tone shall be capable of responding to a message within 2 seconds of ignition key-on.
- In order to provide real-time feedback of the selection/shifting/engagement process of transmission, the device shall respond to the received message within 75 milliseconds.
- Whenever bus communications are active and anytime ETC2/PID 226 message is not received within 5 seconds of the last valid message, annunciator shall be silent.
- Whenever bus communications are not active, annunciator shall be silent.

Service Lamp

Fuller UltraShift *PLUS* models (LAS, LSE, MXP, MHP, VAS, VCS, VHP, VMS and VXP) provide a wired service lamp output at J1-23. This output is designed to drive an incandescent lamp of 1.0 watt or less. An alternate LED indicator may be used. The service lamp output will supply a positive voltage equal to the vehicle battery voltage to turn the service lamp on. The OEM shall supply the service lamp ground connection.

Note: If the shift device used does not provide a service lamp one must be added to the dash.

OEM Vehicle Equipment Programming Station (VEPS)

Refer to OEM VCP documentation for configurable VEPS parameters or use Service Ranger tool.

PTO Inputs and Configurations

Engine Driven PTOs

- Engine driven PTOs are compatible with UltraShift *PLUS* transmissions, for both stationary and mobile operation.
- Engine driven PTOs can be used in conjunction with countershaft and split shaft PTOs.
- When an Engine driven PTO is used with an UltraShift *PLUS* transmission, the transmission configuration must be set to: Engine Driven PTO set to: Enable. This can be done with either VEPS or ServiceRanger.
- The PTO active switch is NOT used for engine driven PTOs.
- While in mobile operation, the system is programmed to work well in most situations, however shift quality may be less than ideal under high PTO loading conditions.

Transmission Mounted PTO Inputs

Hardwiring a status switch into the Transmission ECU

Note: Transmission mounted PTOs include countershaft, through-shaft and rear mounted PTOs.

Whenever a PTO device is used, other than an engine mounted PTO, Eaton requires the OEM provide a “PTO active” input to the transmission ECU. The vehicle interface harness shall be pre-populated at the ECU 38-way connector with wiring and a connector needed to connect the PTO. This connector will contain the input and return wire necessary to support the input function.

IMPORTANT: If a Split Shaft PTO device is used, whether in conjunction with a Transmission mounted PTO or not, the PTO input switch must be located on the Split Shaft PTO, this only applies to hard wired applications, if J1939 status is used the switch and wiring are not used.

Note: Must use a dedicated return on Pin 34, frame grounds are not acceptable.

Note: Refer to Cable and Harness Construction section for correct wire and terminal pin sizes for communication and control wires.

- PTO input shall be a normally open switch.
- The switch shall close to the PTO return line (pin 34) whenever the PTO is activated. This input activates the PTO mode of the transmission. This feature uses pin 18 and 34 of the transmission connector, see illustration.
- The input signal wire for the PTO shall be isolated from other PTO related circuits.
- The ground connection shall be isolated from local power device ground returns.

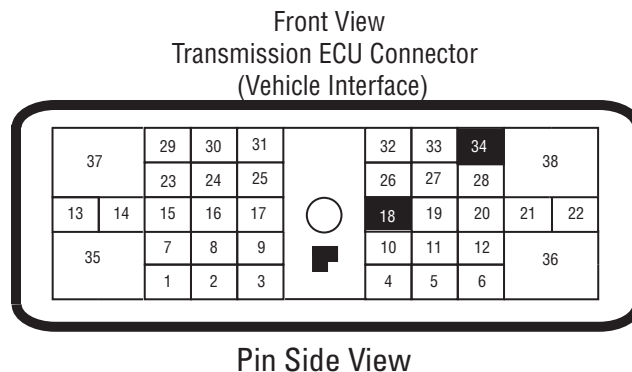

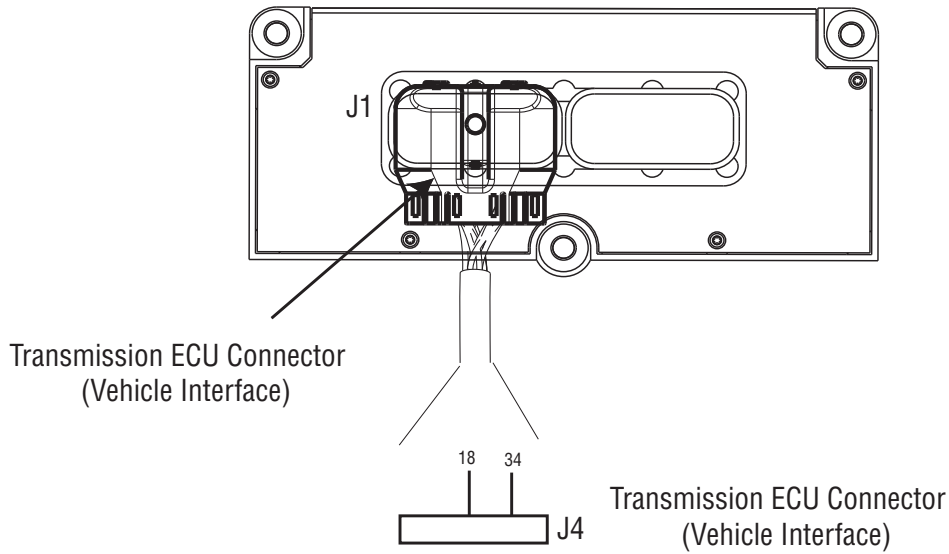

From	Description
J1-18	PTO Signal Input
J1-34	PTO Return

Transmission Mounted and Split Shaft PTO Configurations

The transmission ECU contains configuration software for PTO mode. Transmission mounted PTOs include countershaft, through-shaft and rear mounted PTOs, if any of these PTOs are used the transmission ECU configuration “Counter Shaft PTO” shall be set to “Enabled”. If a Split Shaft PTO is used the transmission ECU configuration “Split-Shaft PTO” shall be set to “Enabled”. VEPS or the Eaton ServiceRanger tool may be used to change these configuration settings.

⚠ WARNING

Counter Shaft PTOs may be used in conjunction with a Split Shaft PTO device, however the configuration settings for both “Counter Shaft PTO” and “Split Shaft PTO” shall be set to “Enabled”.

Split Shaft Power Take Off (SSPTO)

Integration is required for proper operation of Fuller UltraShift PLUS models (LAS, LSE, MXP, MHP, VAS, VCS, VHP, VMS and VXP). A SSPTO shall interface with any Fuller UltraShift PLUS product by either:

- Hardwiring a status switch into the Transmission ECU
 - See Section 7: Transmission Mounted PTO Inputs " for instructions on hard wiring SSPTOs into the UltraShift PLUS transmission
- SAE J1939 communication (preferred)
 - If the appropriate messages are detected, the Transmission ECU will automatically select this method and ignore the terminal input
 - Using this method provides additional functionality, such as the ability to remotely command the transmission to shift gears and engage the clutch

WARNING

Accurate state of the SSPTO is critical to driver and vehicle safety.

Operating Procedure for the Hardwired Option

- The truck must be idling in Neutral with the parking brake applied.
- Use SSPTO control switch installed by the OEM or truck equipment manufacturer to actuate the SSPTO. This will change the state of the switch wired into the UltraShift PLUS controller.

IMPORTANT: Failure to confirm SSPTO has removed the connection to the drive tires can cause unintended truck movement and potential injury to persons and damage to equipment.

- Using the in-cab shift device, place the transmission in Manual/Hold Mode. The transmission is now engaged in the SSPTO Default Gear. This default setting can be changed using ServiceRanger. The factory setting is direct drive. If a mode other than Manual/Hold is selected, the transmission will AutoNeutral.
- Use of the Upshift and Downshift button on the shift device will cause the transmission to change gears within the boundaries of the minimum and maximum gears set using ServiceRanger. The factory setting allows only gears in high range excluding overdrive ratios. This can be modified using ServiceRanger.
- When ready to engage the SSPTO, apply the accelerator pedal in any amount for 3 seconds. This will cause the automated clutch to close and supply power through the transmission to the SSPTO.
- A Remote Throttle can now be used to control engine speed.
- Applying the service brake will cause the automated clutch to open. Selecting Neutral on the shift device will cause the clutch to open, but will also put the transmission in neutral.

IMPORTANT: Never actuate the SSPTO control switch unless the transmission is in Neutral.

- Return the SSPTO control switch to its original position to allow the engine to power the drive tires.
- The transmission and shift device will now work as usual for driving of the vehicle. This can only happen once the hard-wired signal from the SSPTO indicates the SSPTO is no longer engaged.

J1939 Interface Method

- Use of J1939 to interface a SSPTO with the UltraShift PLUS transmission requires unfaulted ABS and Parking Brake systems.
- Use of J1939 to interface a SSPTO with the UltraShift PLUS transmission requires the SSPTO to be represented on the J1939 network by a dedicated network node with a unique source address.
- The following messages and signals are involved in implementing the J1939 interface:

Message	Parameter Group Name (PGN)	Parameter Name	Suspect Parameter Number (SPN)	Start Bit	Length	Value	Description
PTODE	64932	EngagementStatus	3462	34	2	00	DriveNotEngaged
						01	DrivesEngaged
						02	Error
						03	NotAvailable
TC1	256	TransMode3	1854	44	2	00	Disable
						01	Engable
						02	Reserved
		TransRequestedGear	525	16	8	247	Downshift 1 Gear
						249	Upshift 1 Gear
						253	Hold Current Gear
Requested%ClutchSlip	684	8	8	0-100	0-99%=Closed 100%=Open		
ETC7	65098	TransMode3Indicator	2538	18	2	00	DriveNotEngaged
						01	DrivesEngaged
						02	Error
						03	NotAvailable

All values listed here and in the text are in decimal unless otherwise noted

This table is provided for convenience, consult the latest SAE J1939 standard for additional information

Split Shaft PTO J1939 Communication Process

- Truck must be idling in Neutral with the parking brake applied.
- SSPTO controller shall constantly send Engagement Status every 100ms with a value of “00” indicating SSPTO is not engaged.
- Once the SSPTO has been successfully actuated, Engagement Status shall carry a value of “01” indicating the SSPTO is engaged. The method for actuating the SSPTO is left to the OEM or truck equipment manufacturer.

IMPORTANT: Failure to confirm SSPTO has removed the connection to the drive tires can cause unintended truck movement and potential injury to persons and damage to equipment.

- When the SSPTO controller is ready to control the transmission, use the following commands to place transmission in SSPTO Mode:
 - TransMode3 with a value of “00” initially to indicate Transmission Mode 3 is NOT requested.
 - TransMode3 with a value of “01” to indicate Transmission Mode 3 IS requested.
- The UltraShift *PLUS* controller will update TransMode3Indicator in the ETC7 message from the transmission to indicate if the request for Transmission Mode 3 has been honored.

- To take transmission out of split shaft PTO mode:
 - When SSPTO control of the transmission is no longer needed TransMode3 needs to be set to “00” to indicate Transmission Mode 3 is no longer requested.

Note: If using remote clutch operation, the clutch should be opened before disengaging transmission SSPTO Mode.

IMPORTANT: Transmission Mode 3 requests can only be honored if the truck is stopped, no ABS or parking brake faults are detected, the parking brake is applied, the transmission is in neutral, EngagementStatus of the PTO message has a value of 01, and the request comes from the same source address as EngagementStatus.

- Using the in-cab shift device, place the transmission in Manual/Hold Mode. The transmission is now engaged in the SSPTO default gear. This gear can be changed using ServiceRanger. The factory setting is direct drive. If a mode other than Manual/Hold is selected, the transmission will Auto Neutral.
- Use of the upshift and downshift button on the shift device will cause the transmission to change gears within the boundaries of the minimum and maximum gears set using ServiceRanger. The factory setting allows only gears in high range excluding overdrive ratios. This can be modified using ServiceRanger.

OPTIONAL SSPTO J-1939 Commands

Upshifts and downshifts:

- Use of Trans Requested Gear in the TC1 message is allowed to request single upshifts and single downshifts. Use of TransRequestedGear is not necessary for SSPTO operation over J1939.
 - To request an upshift, send TransRequestedGear with a value of “249”, and then back to a value of “253”
 - To request a downshift, send TransRequestedGear with a value of “247”, and then back to a value of “253”
 - The request is only recognized once the value of “253” is received after a value of “247” or “249”

Clutch control:

- Use of Requested%ClutchSlip in the TC1 message is allowed to remotely close and open the clutch. Use of Requested%ClutchSlip is not necessary for SSPTO operation over J1939; however, if chosen as the method to open and close the clutch, the accelerator pedal cannot be used to close the clutch.
 - To request the clutch to close, send Requested%ClutchSlip as 100% at first, then 0%.

Important: If the Requested%ClutchSlip message is to be used, the accelerator pedal cannot be used to engage the clutch.

- Requested%ClutchSlip to 100% will also open the clutch.
- If Requested%ClutchSlip is not to be used, applying the accelerator pedal for 3 seconds will cause the clutch to ramp closed.
- Should the truck begin to move, the transmission is monitoring ABS wheel speed sensors. If sustained movement is seen, the transmission will Auto Neutral.
- SSPTO Operation can be stopped by applying the service brake or selecting neutral on the shift device. The clutch will ramp open and remove power from the engine to the SSPTO.

IMPORTANT: Never actuate the SSPTO to return power to the wheels unless the transmission is in Neutral.

- When the SSPTO drive is no longer engaged, EngagementStatus needs to be updated with a value of “00” to indicate the PTO is Not Engaged.
- The truck can now be driven normally using the in-cab shift device.

PTO Wiring Diagrams

The typical relay used for PTO wiring is listed below.

- Bosch: 0332-209-151 (+12 volt), 0332-204-203 (+24 volt) or equivalent
- HELLA: 4RD 960 388-22 (+12 volt) (Recommended)
- SIEMENS W28-15F24-S01 (+12 volt)

Note: Use a normally open switch for the PTO “Active” Switch. It can be Mechanical Ball Switch or Air Switch.

Relay Isolated PTO Application

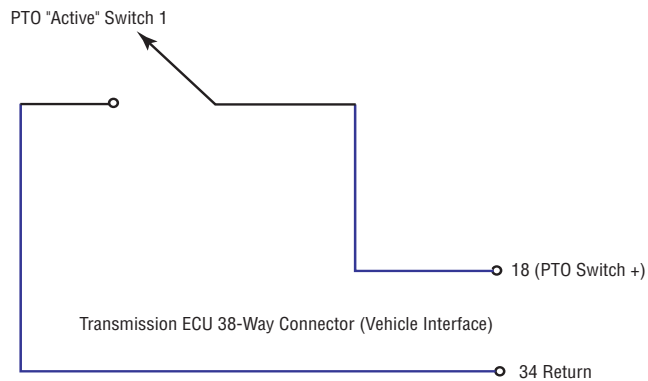
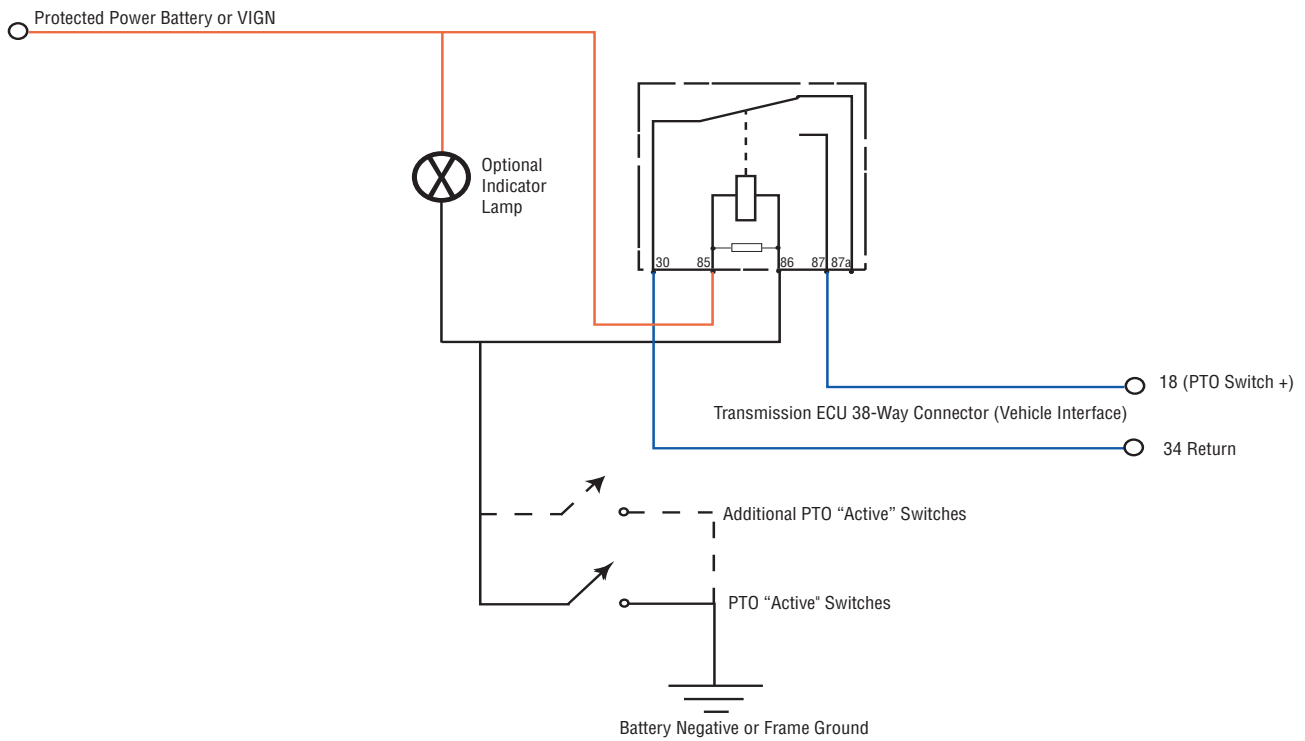

Dual Relay PTO Application (Double Switch)

The dual relay option provides one input for transmission PTO operation and another input for the vehicle.

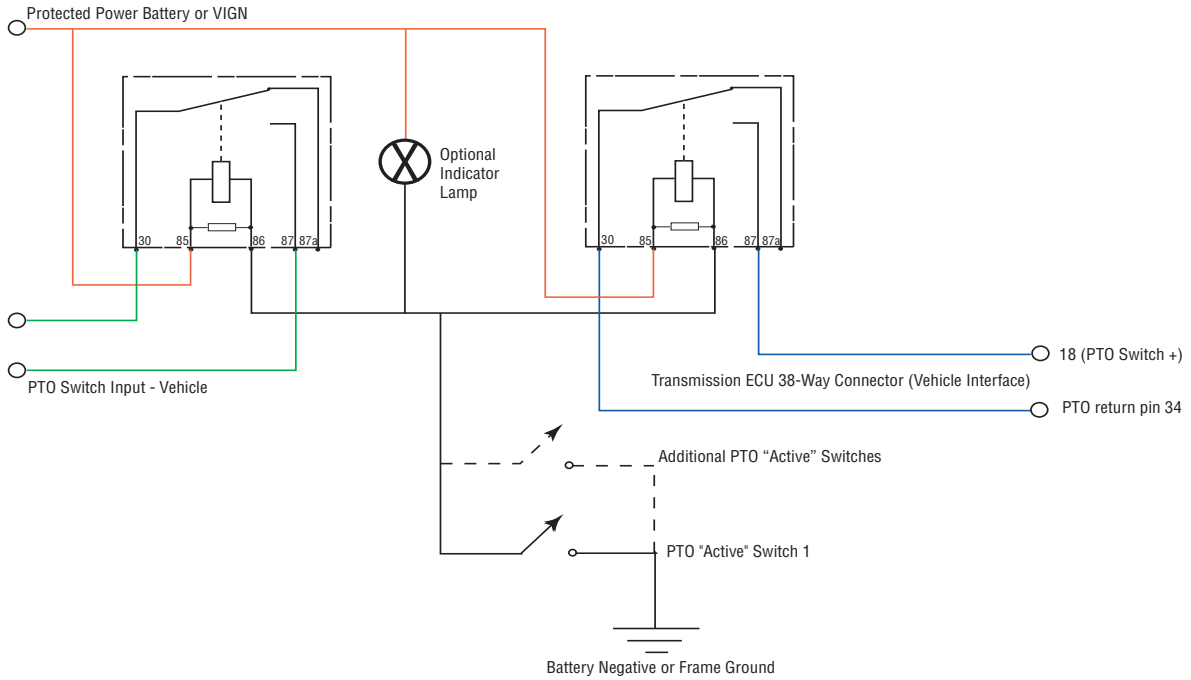

Dual Switch PTO Application

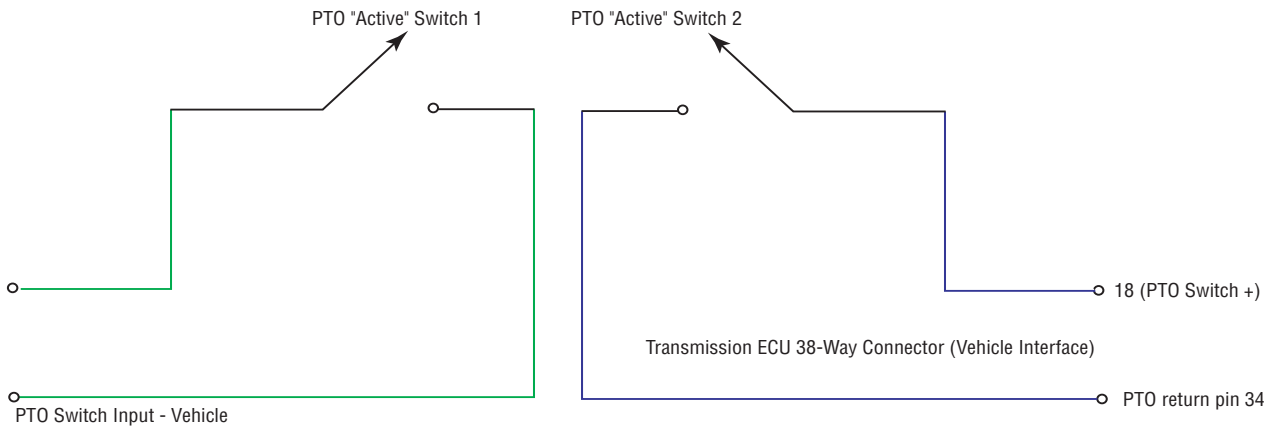

Line Inspection and Road Test Instructions

The checklist was developed as an installation tool for line personnel to ensure the correct operation of each vehicle and to assist the vehicle OEM to identify transmission quality related issues as well as OEM line quality issues. Used correctly, this checklist identifies transmission issues and aids in tracking the problem until corrected.

The recommended use of the checklist is as follows:

1. A separate checklist should be filled out for each vehicle built with Eaton Fuller transmissions. If these checks and information can be combined with an existing form, the Line Inspection form does not need to be used.
2. The section identified as PRE-START CHECKS should be performed prior to the initial start-up of the vehicle. This section ensures the transmission has the correct power supplies, sufficient lubricant, and correct transmission shift tables.
3. Perform any necessary corrective action prior to the dyno or road testing.
4. The DYNO/ROAD TEST section is used to verify that all transmission systems are functional and the Drivers Manual and Shift Label are supplied in the cab.
5. With a record of transmission related information and repairs made to each unit, the OEM is able to track and correct repeated quality issues.
6. A copy of the checklist should be recorded for installation history. OEM line personnel should become familiar with the checklist for the transmission prior to a scheduled build. Eaton OEM Engineering Support Group can coordinate training and information to expedite this process.

This checklist represents a generic system which can be tailored to the individual OEM to achieve the best possible method of transmission installation verification. Eaton recommends the use of this system to maintain the utmost in satisfactory operation and long service life.

Each transmission system installed at the OEM shall pass the line checklist requirements per the Eaton Line Inspection Form prior to shipment from the OEM plant.

Line Inspection

This transmission is equipped with a neutral interlock system that when properly installed prevents the engine from cranking with the transmission in-gear.

 WARNING

Failure to perform installation pre-start checks may result in the engine cranking immediately when ignition is moved to the “START” position or to the “ON” position.

To prevent undesired vehicle movement for new installations, always set the parking brake prior to turning the ignition key “ON” and also prior to attempting “START”.

 WARNING

Improper installation of the OEM Start Enable Circuit could result in enabling the vehicle to be started in gear.

Pre-Start Inspection and Initial Starting Requirements

Pre-Start Inspection

- Verify the transmission has been filled with the correct amount and type of lubricant before starting the engine. Failure to add sufficient lubricant could damage the transmission. See Lubricant Requirement section in this manual for details.

The transmission is equipped standard with an oil level sight glass. When the transmission oil level is at or above 3/4 the sight glass then it is at or above the minimum oil fill level.

To check the oil level with the sight glass:

- Vehicle engine shall be stopped and parked on level ground.
- Wipe dirt from the oil level sight glass.
- When the transmission oil level is at or above 3/4 the sight glass then it is at or above the minimum oil fill level.

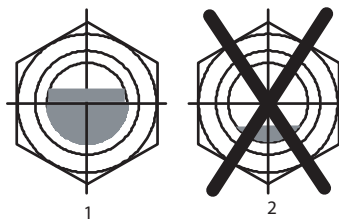

Before Cranking Engine

- Verify Neutral is selected on the shift input device.
- Turn the ignition key to the “On” position and visually observe the power up procedure.

⚠ WARNING

During the initial power up of this transmission, the gear display will show an alternating “N” and “F”. This is a normal occurrence on all Fuller® UltraShift® *PLUS* equipped transmissions. This condition will persist until the initial clutch adjustment and grade sensor calibrations are completed. See following procedures.

- The alternating “N” indicates the transmission has verified neutral.
- The alternating “F” is an indication of an active fault code.
- It is normal for this system to detect an active fault code 27 (clutch adjustment fault) and active fault code 68 (grade sensor calibration fault) during initial power up.
- If the system detects active faults other than 27 and 68, refer to the diagnostic procedure in this manual.

⚠ WARNING

Once the engine has been started, the transmission automatically initiates a clutch adjustment procedure.

- During the clutch adjustment procedure, the operator will be unable to select an active operating mode for the transmission. The shift input device will be locked out from operator request.
- The clutch adjustment procedure could take up to 35 seconds to complete.
- The clutch adjustment procedure will continue even if the engine is shut off.

Note: Once the clutch adjustment is complete, Eaton requires the grade sensor be calibrated prior to dyno. Refer to the following procedure.

⚠ WARNING

Failure to calibrate the grade sensor prior to dyno may lead to unsatisfactory shift performance. This condition could be misinterpreted as a product defect and could lead the operator to unnecessary repair.

Grade Sensor Calibration

Process Requirements:

- Vehicle must be on level ground before initiating the grade sensor calibration.
- Ground surface must be within +/-0.5% grade (.28 deg) level.

 WARNING

Failure to adhere to ground surface conditions may lead to unsatisfactory shift performance. This condition could be misinterpreted as a product defect and could lead the operator to unnecessary repair.

- Verify the suspension is fully aired.
- Verify the suspension is set to proper ride height.
- Engine shall not be running during the grade sensor calibration.

There are three options for completing the grade sensor calibration. The process for each option is listed below. Your OEM may implement any of these processes.

Grade Sensor Calibration Tool

1. Key On
2. Engine shall not be running
3. Plug grade sensor calibration tool into 9-pin diagnostic connector
4. Push the button on top of tool
5. Observe the pass/fail indicator on top of tool
 - If indicator is green, the calibration was successful.
 - If indicator remains red, the calibration failed.

 WARNING

If the grade sensor fails to calibrate, refer to the diagnostic procedure in this publication.

Shift Input Device Combination

1. Begin with the ignition key off
2. Turn the ignition to the ON position but do not start engine
3. Select “L” on the shift input device. At this point, do not press the brake pedal
4. Press the “Up” arrow once, the gear display should change to 0
5. Press the “Up” arrow five times, the gear display should change to 6
6. Depress the accelerator all the way to the floor and hold until down arrow is shown in the gear display, may take approximately 2 seconds
7. Release the accelerator, the gear display should revert back to 0

Note: At this point, the grade sensor offset should be calibrated.

8. Select “N” on the shift input device, the gear display should no longer be flashing an “F”

ServiceRanger (PC-based Diagnostic Tool)

1. Turn ignition switch to On.
2. Plug 9-pin connector into dash port.
3. Click on ServiceRanger icon to launch program.
4. Click on “Go To” and select “Service Routines”.

Note: All available Service Routines will be shown.

5. Click on the “Start” button next to Grade Sensor Calibration.

Note: Read the on screen instructions and ensure that the vehicle meets the requirements for Grade Sensor Calibration.

6. Click on “Calibrate”.
7. Wait for the message “Successful: The Grade Sensor Calibration was successful.”
8. Verify that Fault Code 68 FMI 13 has gone inactive.
9. Click on “Disconnect” and close ServiceRanger,
10. Disconnect computer from dash port.

Note: If Fault Code 68 is active, see Troubleshooting Guide TRTS0940.

11. Turn ignition switch to Off.

Line Inspection Form - Fuller UltraShift *PLUS* models

Note: The service brake input is required while selecting a starting gear. If the service brake is not applied while selecting a starting gear, the initial start gear will not be found and the driver will have to re-select neutral and press the brake while re-selecting the desired mode.

Note: When testing on a dynamometer which decelerates quickly, the display module may not appear to function correctly. Should this occur, drive the vehicle off the dynamometer and note how the display functions. If it functions correctly when driving, the problem is that the dynamometer decelerates too quickly.

Fuller UltraShift <i>PLUS</i> models (LAS, LSE, MXP, MHP, VAS, VCS, VHP, VMS and VXP)	OEM:		
Line Inspection	Chassis S/N:		
	Transmission Model:	Transmission S/N:	
Description			
	Yes	No	Corrected
Pre-Start Checks			
1.	Ignition Bus Check: Does service light turn on and tone sound?		
2.	Power Supply check: (manual reset type) or fuse		
	30 amp Main Power for Transmission ECU		
	40 amp Main Power for Transmission ECA		
3.	Power up procedure: System powers up and "N" on Gear Display		
DYNO/Road Test Checks			
1.	Verify the engine doesn't crank in any position other than neutral		
2.	Verify the Auto Neutral function		
3.	Verify forward and reverse gear not obtained without service brake applied		
4.	Verify all forward and reverse gears are obtained with engine control		
5.	Verify engine ECU contains proper configuration settings		
6.	Verify transmission temperature gauge is functional - if equipped		
7.	Verify gear display module works correctly		
8.	Verify hill start aid switch flashes when selected		
9.	Verify shift input device panel lights are functional		
10.	Verify no transmission oil leaks or residue		
11.	Verify the transmission diagnostic connector is accessible		
12.	Verify correct Shift Label		
13.	Verify lubricant type and brand label affixed to transmission fill plug		
14.	Oil Fill - With engine off, verify proper lubrication level. Refer to Lubrication Requirements section of this manual.		
15.	Clear Fault Codes and verify diagnostic connector functions		
16.	Prior to shipment of Eaton Automated Transmission Systems installed at OEM plants, the engine ECU shall contain the proper configuration settings. For the proper engine configuration settings required for Eaton Automated Transmission operation refer to the "Engine Configuration Settings Installation Guide" on roadranger.com under the literature center.		
Comments:			
Final Inspection Date:			
Signature:			

Line Inspection Form OEM Wiring Connector/Harness

Note: Eaton requires the checklist items to be incorporated into the OEM control plans.

Description	Yes	No	Corrected
Deutsch Connector to Transmission ECU 25 +/- 3 lbs. in. [2.82 +/- .33 N•m]			
Packard Connector to Push Button Controller 10 +/- 3 lbs. in. [1.1 +/- .33 N•m]			
NyoGel 760G lubricant is recommended on connector contacts			
No lubricant or foreign material on connector jackscrew			
No contaminants on connector contacts			
Harness anchor points within 6 in. [15.24 cm] of connectors			
No unanchored length of harness greater than 12 in [30.48 cm]			
No sharp bends in the harness			
Tie wraps on Harness Jacketing only			
Harness not anchored to objects that are free to move			
All connectors are fully mated and latches locked			
All unused connectors or pins should be plugged			
No exposed splices or wire strands			

Note: Eaton requires the above checklist items to be incorporated into the OEM control plans.

Diagnostic Procedures

A *Purpose: Document the vehicle symptoms and determine if the engine will crank.*

1. Document the vehicle symptoms by completing the *Driver Questionnaire* on page 8.
2. Key on with engine off.
3. Attempt to start the engine.
 - If engine does not crank, go to **Step B.**
 - If engine cranks, go to **Step D.**

B *Purpose: Observe gear display.*

1. Key on with engine off.
2. Observe gear display.
 - If “F” appears in gear display, go to **Step H.**
 - If “-” (1 dash) appears in gear display, go to **Step C.**
 - If “- -” (2 dashes) or “* *” (2 stars) appears in gear display, perform the *Power-Up Sequence Test* on page 23.
 - If gear display is blank, perform the *Power-Up Sequence Test* on page 23.
 - If “N”, appears in gear display perform the *Start Enable Contact Test* on page 397.

C *Purpose: Check for Active or Inactive fault codes.*

1. Key on with engine off.
 2. Connect ServiceRanger.
 3. Retrieve Snapshot and VPA data by creating a *Service Activity Report* within ServiceRanger.
 4. Update transmission software to latest available level.
-  **Caution:** To avoid damaging the TECU, use an Eaton-approved communications adapter and ensure all satellite systems are disabled before updating software.
5. Retrieve and record the transmission fault codes and FMIs, and their occurrences and timestamps.
 - If Active fault codes are present, go to **Step H.**
 - If no Active fault codes are present, perform the *Main Case Control Test* on page 429.

D *Purpose: Confirm transmission engages a gear from neutral.*

1. Attempt to engage a gear from neutral.
 - If transmission engages a gear, go to **Step E.**
 - If transmission does not engage gear and the gear display shows a solid number, perform the *Main Case Control Test* on page 429.
 - If transmission does not engage gear and the gear display shows anything else, perform the *Transmission Not Engaging a Gear From Neutral Test* on page 437.

E ***Purpose:** Operate vehicle and attempt to recreate vehicle symptom.*

1. Drive or operate vehicle and attempt to set a fault code or duplicate the previous complaint.
 - If a problem is duplicated, go to **Step F.**
 - If no problem is duplicated, go to **Step G.**

F ***Purpose:** Check for Active or Inactive fault codes.*

1. Key on with engine off.
2. Connect ServiceRanger.
3. Retrieve Snapshot and VPA data by creating a *Service Activity Report* within ServiceRanger.
4. Retrieve and record the transmission fault codes and FMIs and their occurrences and timestamps.
 - If fault codes are present, go to **Step H.**
 - If no fault codes are present, match the vehicle symptoms from the test drive and *Driver Questionnaire* to the *Symptom-Driven Diagnostics Index* on page 10.

G ***Purpose:** Check for Active or Inactive fault codes.*

1. Key on with engine off.
2. Connect ServiceRanger.
3. Retrieve Snapshot and VPA data by creating a *Service Activity Report* within ServiceRanger.
4. Retrieve and record the transmission fault codes and FMIs and their occurrences and timestamps.
 - If fault codes are present, go to **Step H.**
 - If no fault codes are present, no problem was identified, Test Complete. If additional troubleshooting support is required, contact Eaton at (800) 826-4357.

H

Purpose: *Prioritize fault codes for troubleshooting.*

1. Key on with engine off.
 2. Connect ServiceRanger.
 3. Retrieve and record the transmission fault codes and FMIs, and their occurrences and timestamps.
 4. Determine which fault code to troubleshoot first by using the priority index below (with 1 highest priority and 4 least priority).
 - Priority 1: 11, 12, 81, 84, 85, 99
 - Priority 2: 15, 16, 19, 26, 27, 33, 34, 35, 36, 37, 61, 63, 66, 67, 74
 - Priority 3: 13, 14, 17, 21, 22, 29, 43, 44, 46, 51, 52, 56, 57, 58, 64, 65, 68, 83
 - Priority 4: 41, 42, 45, 71, 72, 73
 - Troubleshoot the fault code with the highest priority level. If more than one fault code within a level applies, troubleshoot Active fault codes before Inactive fault codes.
 - If only Inactive fault codes are present, troubleshoot the fault code that has the highest occurrence count or most recent timestamp.
 - If no fault codes are found, match the vehicle symptom to the appropriate item in the *Symptom-Driven Diagnostics Index* on page 10.
-

Remote Throttle - OEM Requirement

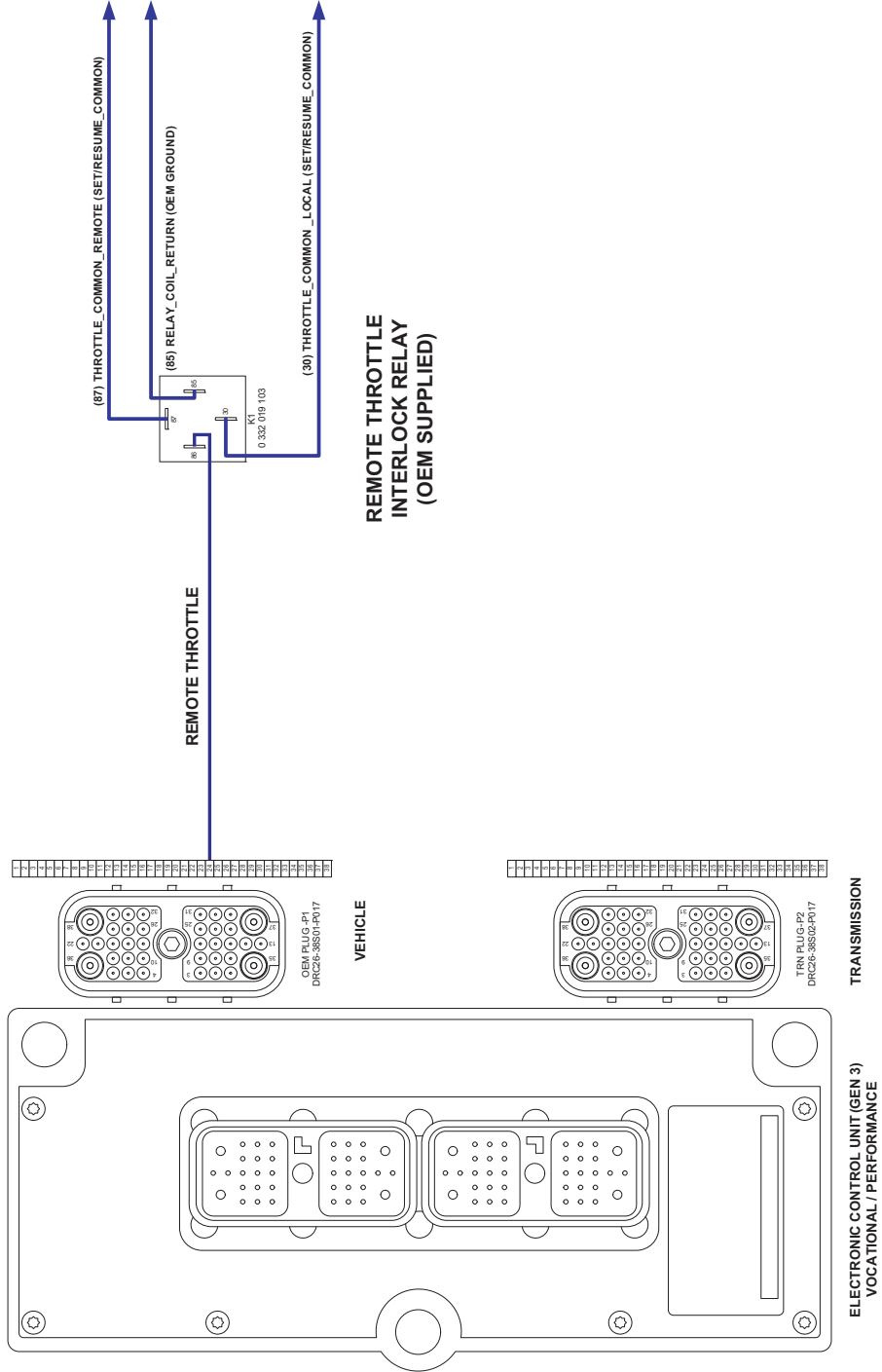

Remote Throttle Options - Remote Switch Only

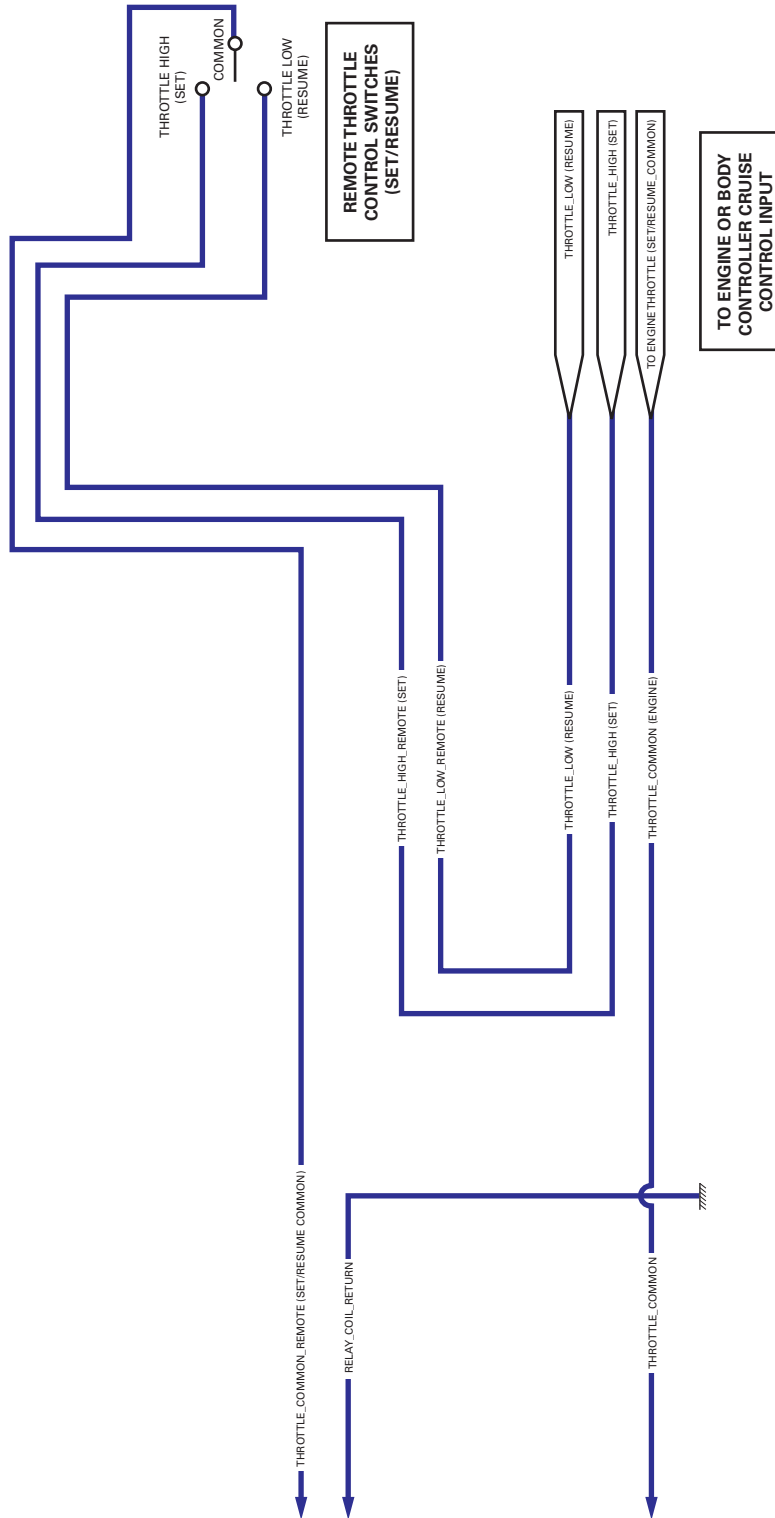

Remote Throttle Options - In Cab Switch with Hard-Wired Remote

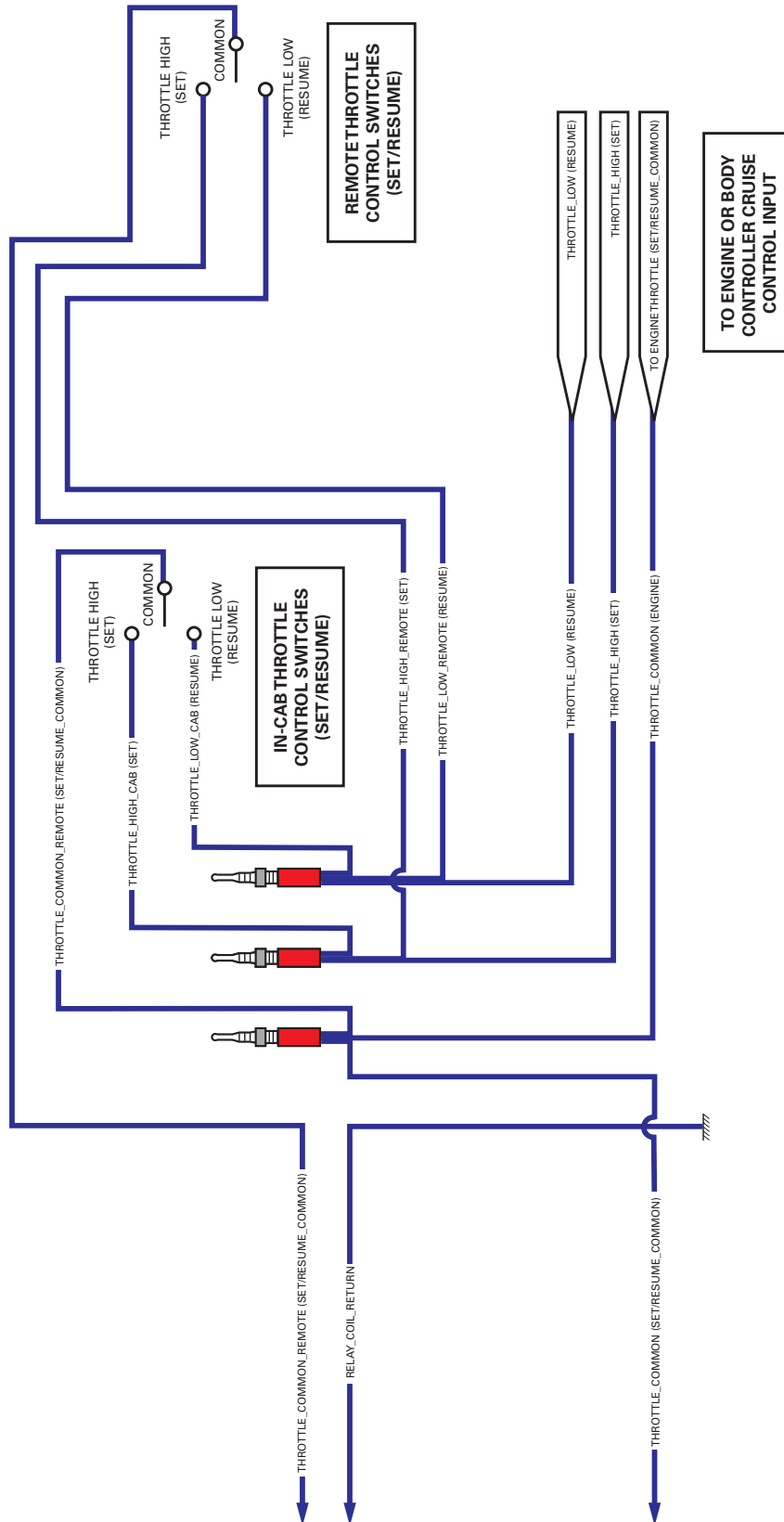

Remote Throttle Options - In Cab Switch with In-line Remote Connector

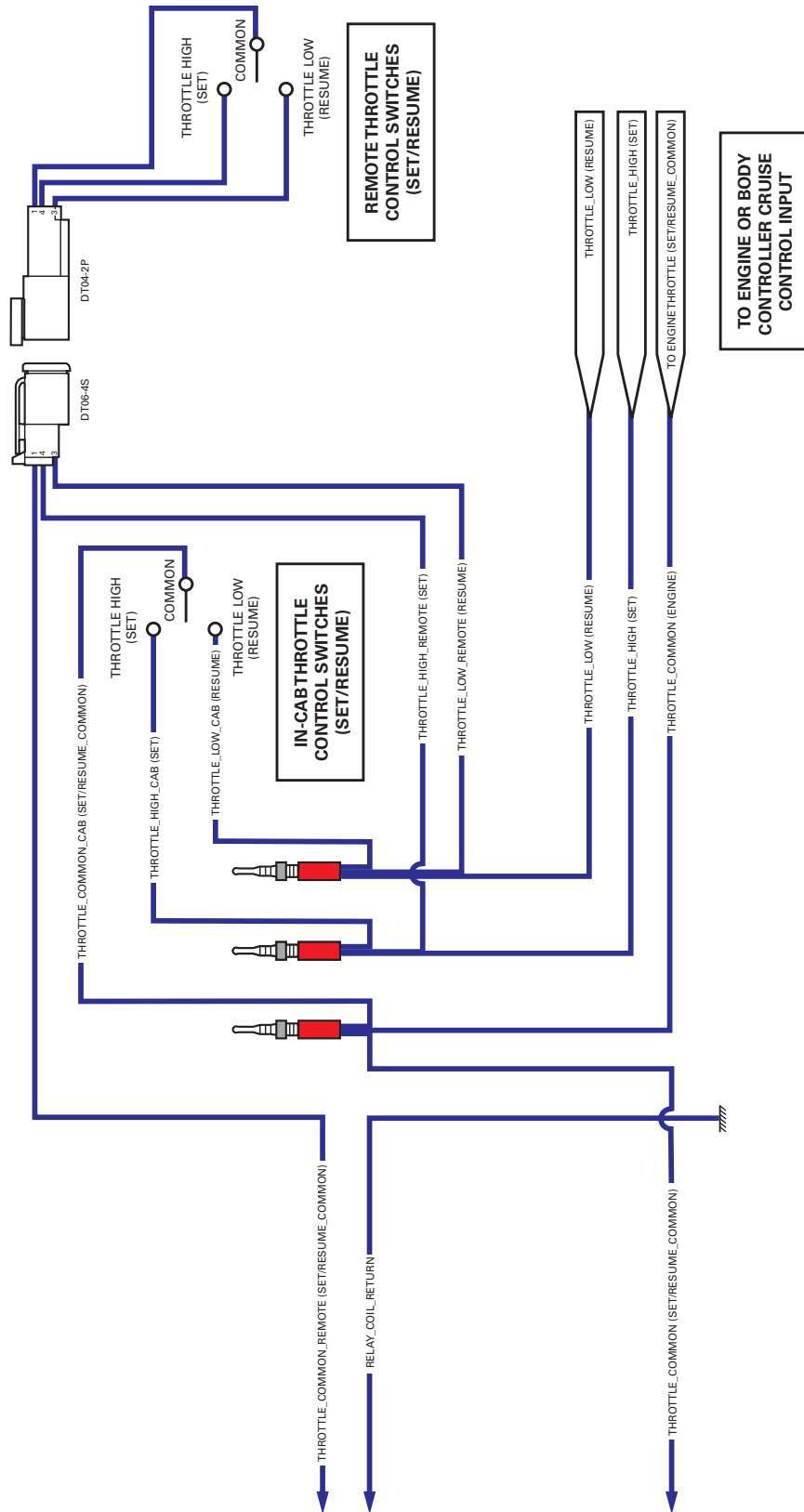

Wiring Diagram - OEM Responsibility

UltraShift PLUS LAS, LSE, MXP, MHP, VAS, VCS, VHP, VMS and VXP with Eaton Shift Lever

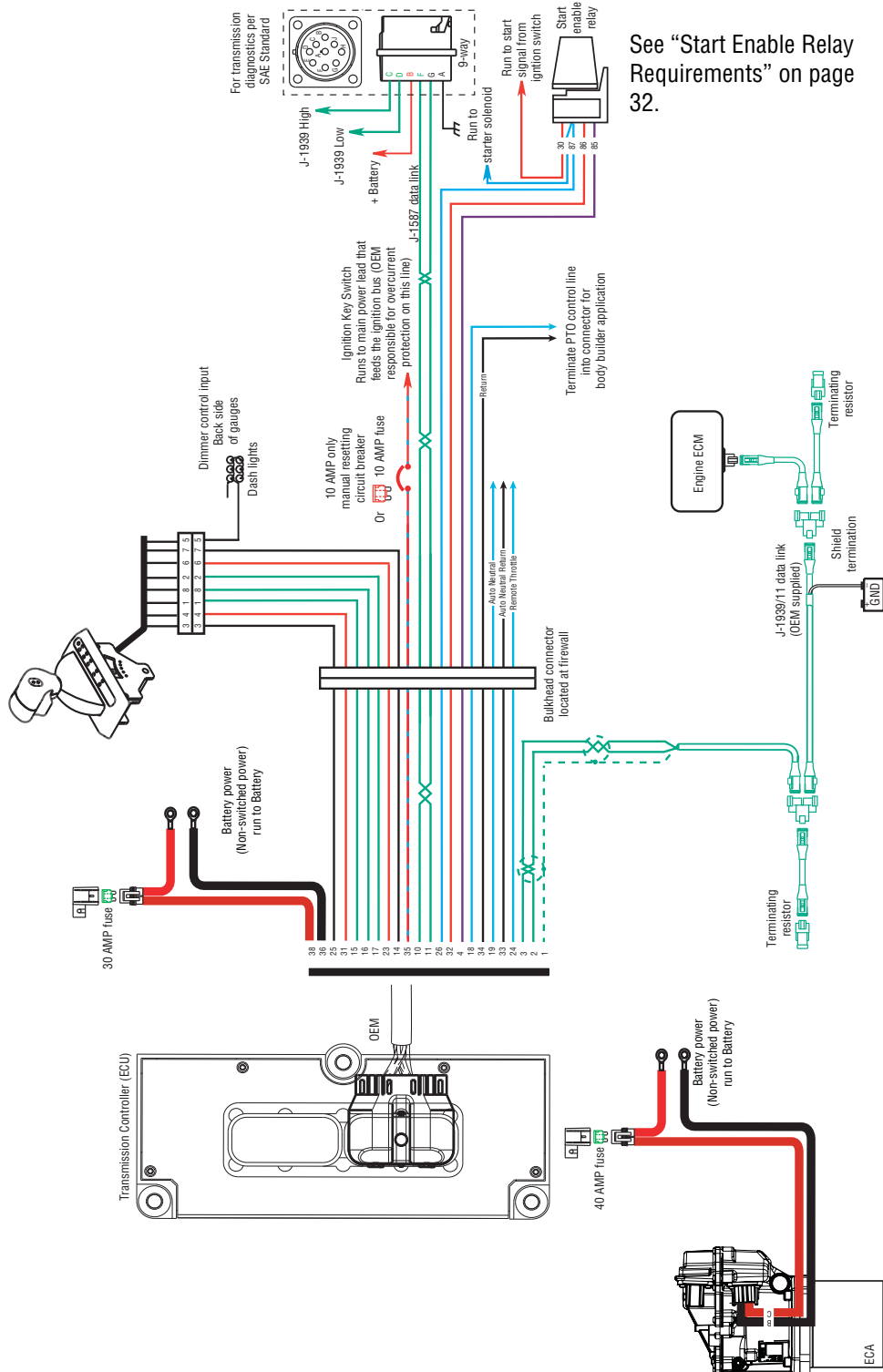

Electrical Requirements

UltraShift PLUS LAS, LSE, MXP, MHP, VAS, VCS, VHP, VMS and VXP with Eaton Push Button

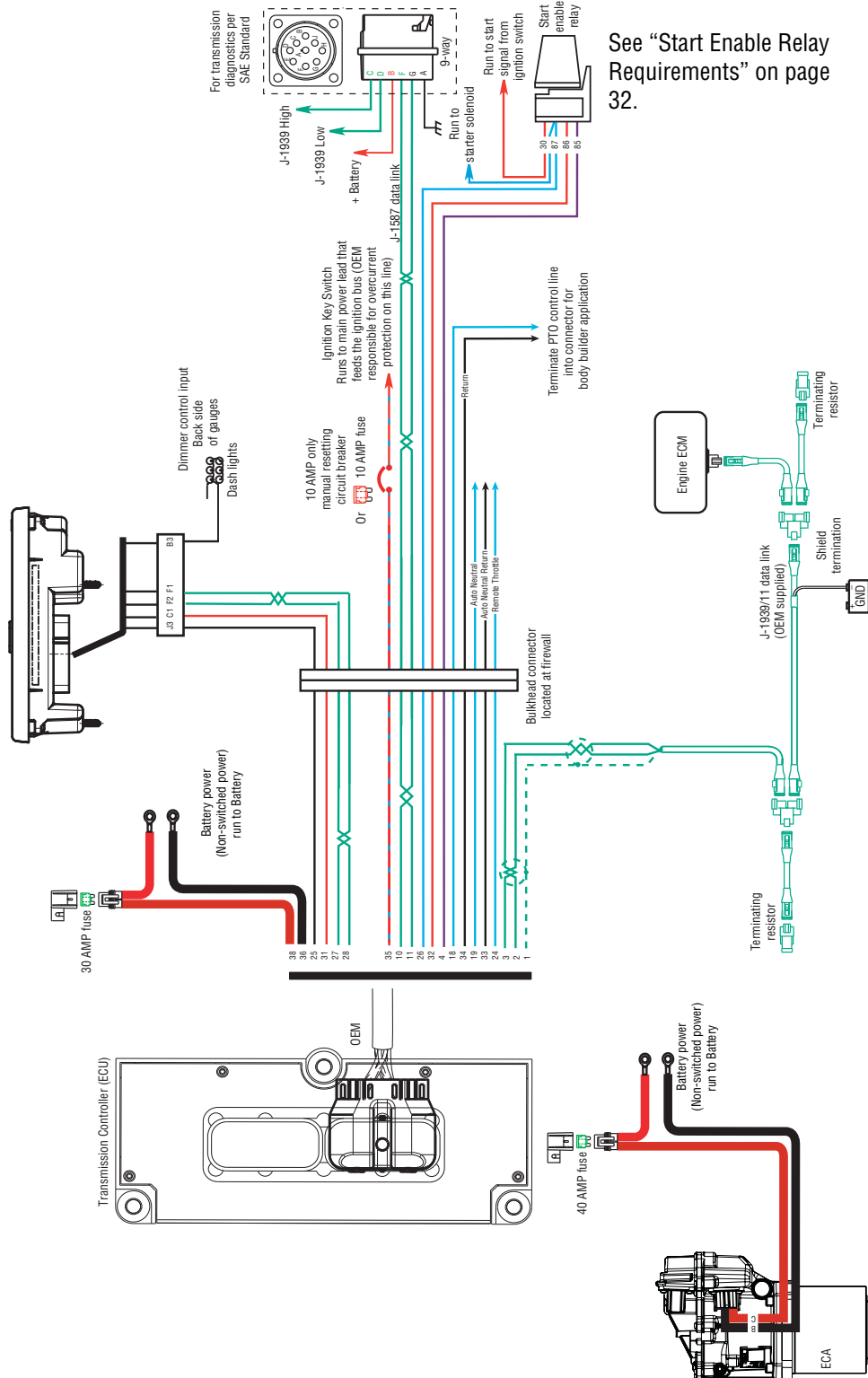

Electrical Requirements

UltraShift PLUS LAS, LSE, MXP, MHP, VAS, VCS, VHP, VMS and VXP Wiring Diagram with Analog Shifter

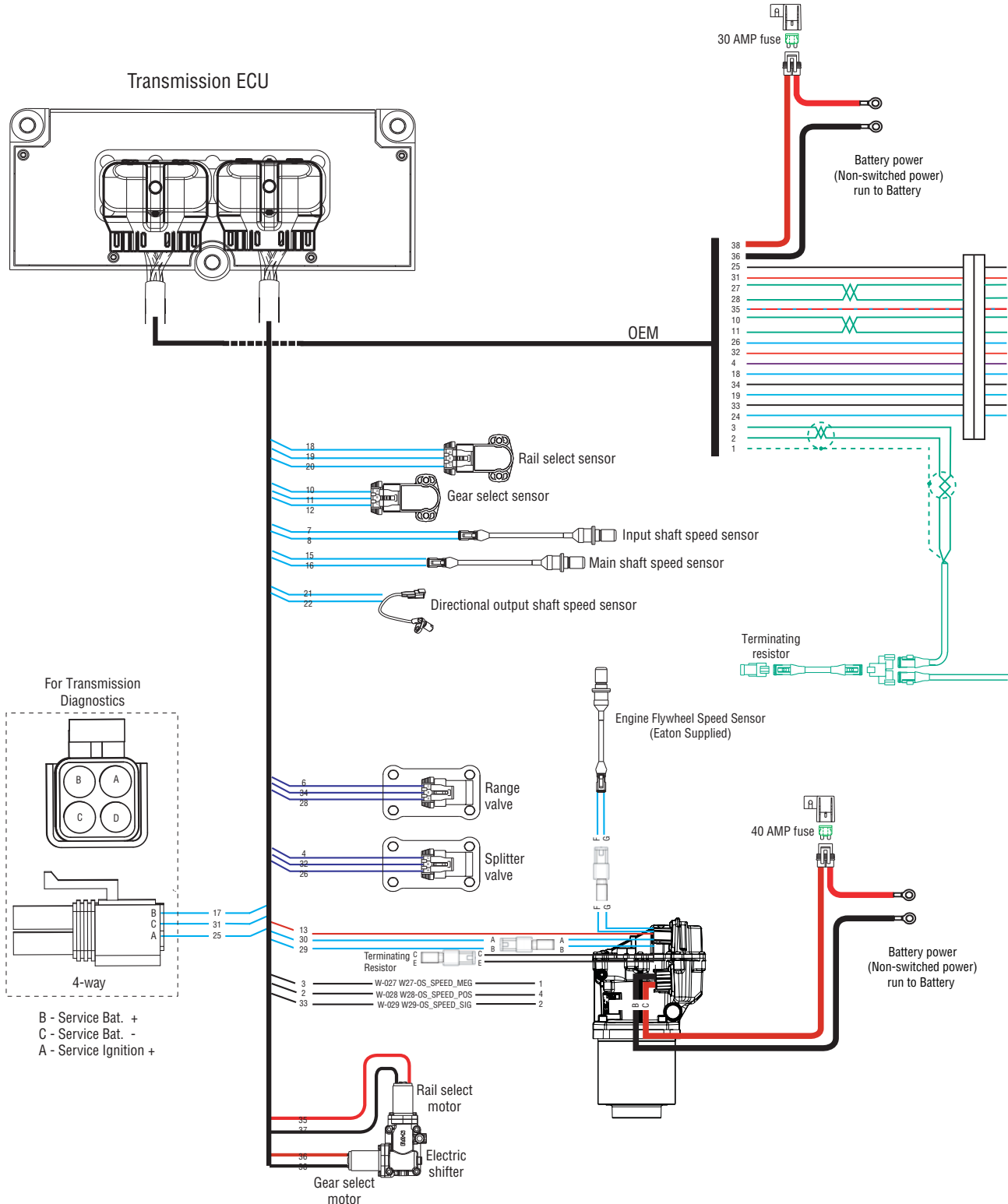

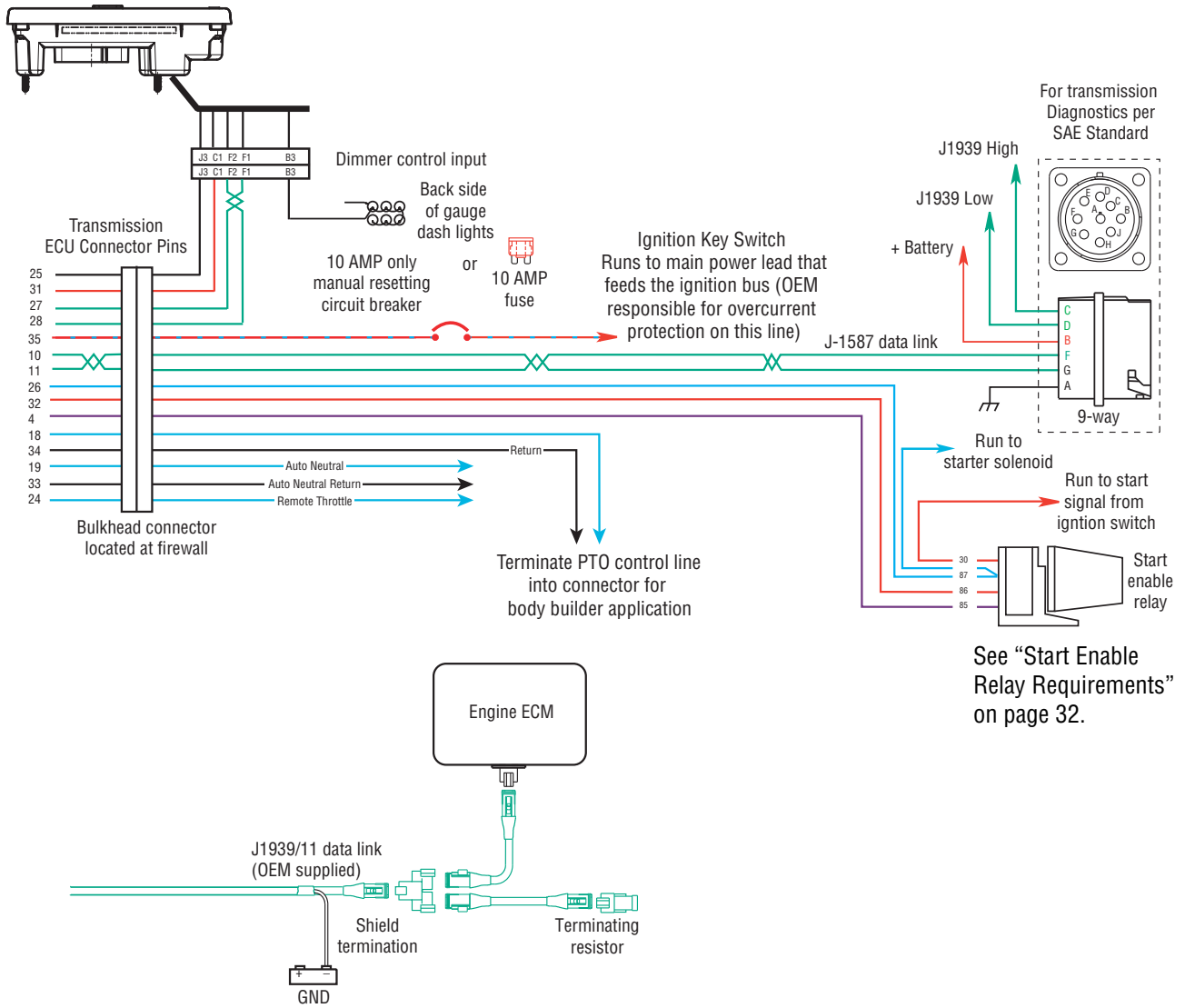

UltraShift PLUS LAS, LSE, MXP, MHP, VAS, VCS, VHP, VMS and VXP Wiring Diagram with Push Button Shifter

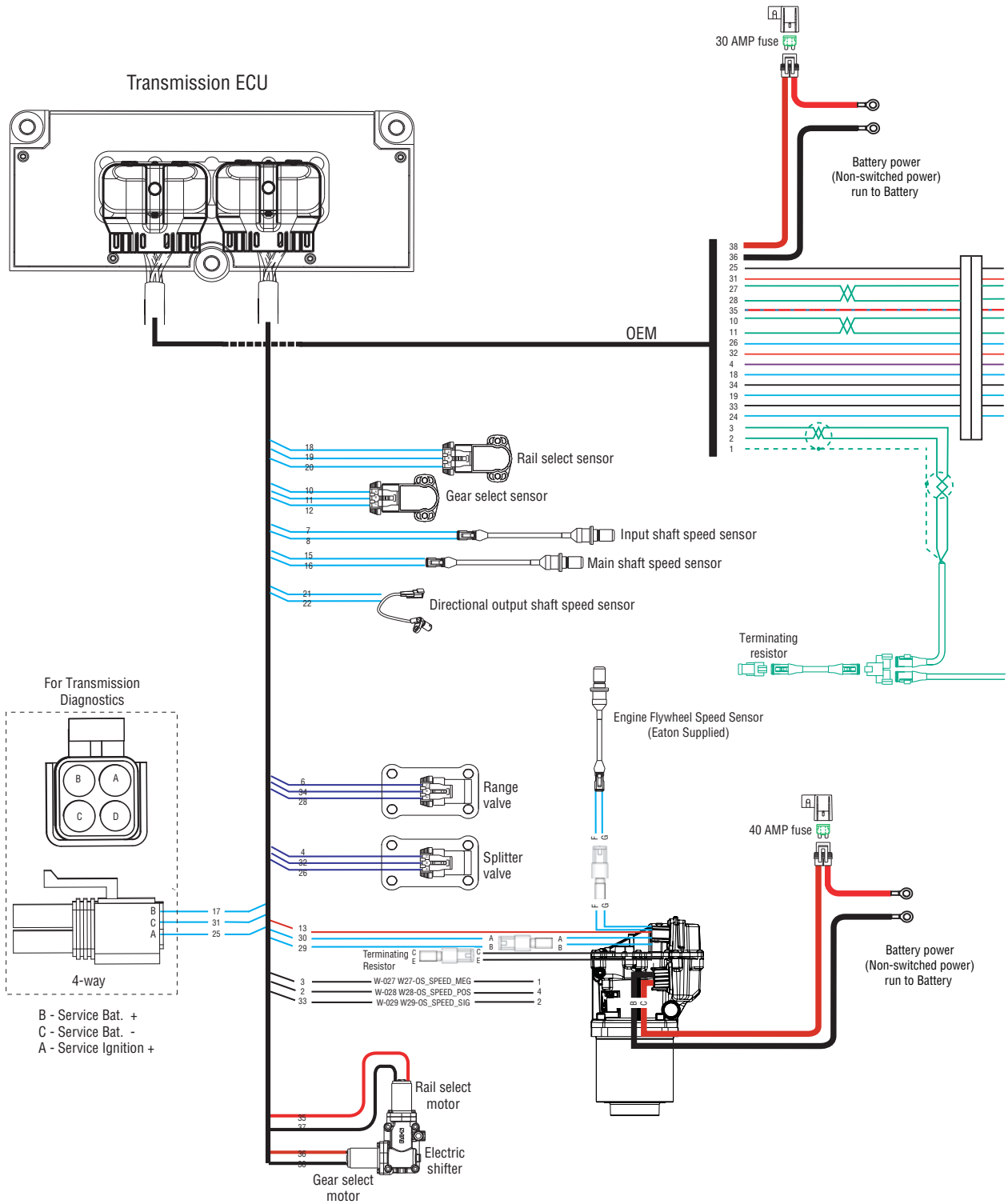

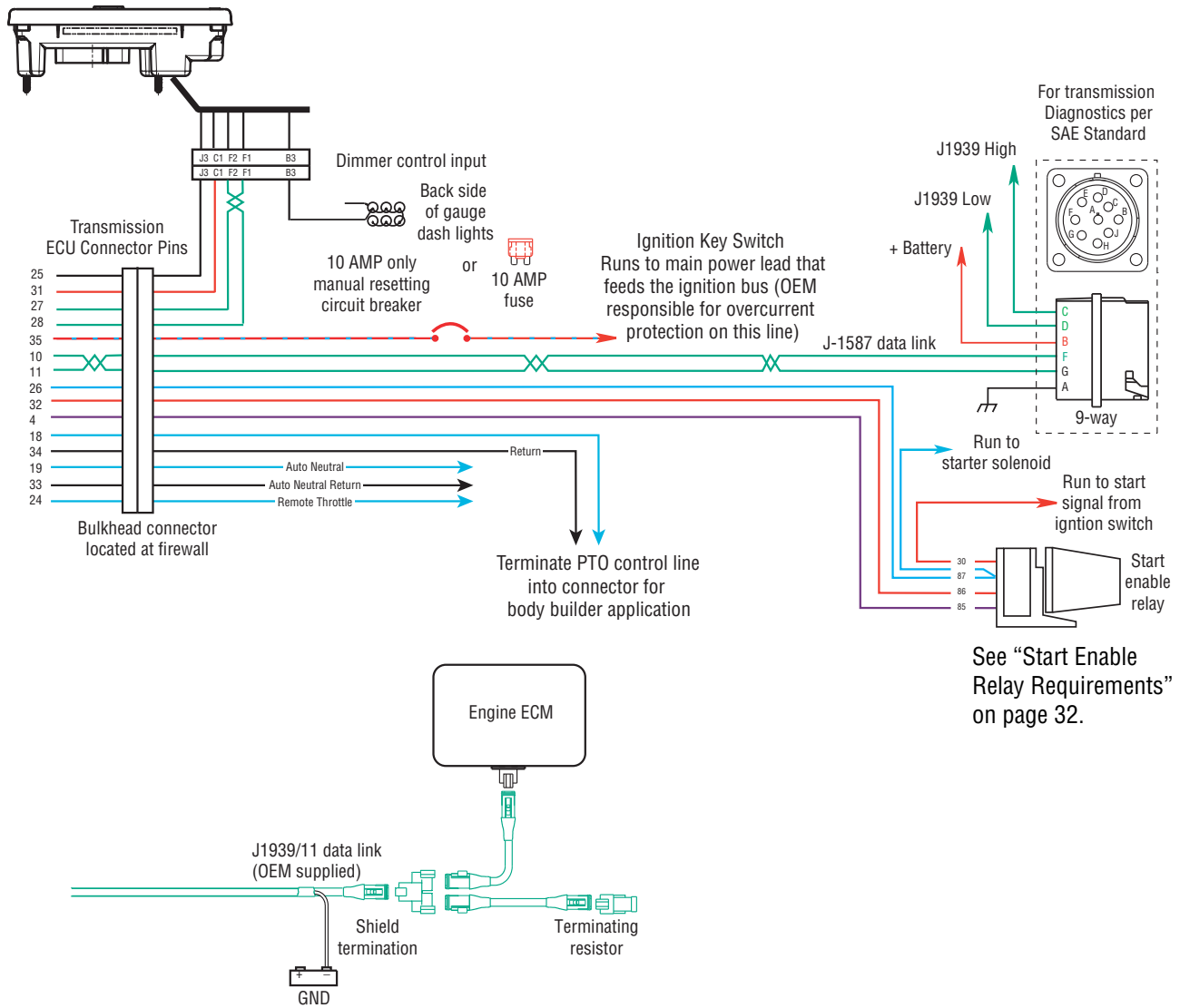

Connector Pin Descriptions

Transmission Controller 38-Way (Vehicle Interface Connector)

38-WAY	Description
1	J1939 Shield (CAN)
2	J1939 Low (CAN)
3	J1939 High (CAN)
4	Start Enable Relay Minus
5	Plugged
6	Plugged
7	Plugged
8	Plugged
9	Plugged
10	J1587 Plus
11	J1587 Minus
12	Aux Transmission signal
13	Aux Transmission return
14	Shift Control Input (Mode Common/Neutral Return 2)
15	Shift Control Input (Mode Auto)
16	Shift Control Input (Mode Manual/Neutral Signal)
17	Shift Control Input (Mode Common/Neutral Return)
18	PTO Signal Input
19	Auto Neutral Signal Input

38-WAY	Description
20	Plugged
21	Plugged
22	Plugged
23	Service Light Output
24	Remote Throttle
25	Shift Control Power Minus
26	Start Enable Latch
27	HIL Low (Proprietary CAN)
28	HIL High (Proprietary CAN)
29	Plugged
30	Plugged
31	Shift Control Power Plus
32	Start Enable Relay Plus
33	AutoNeutral Return
34	PTO Return
35	Ignition
36	Battery Minus
37	Plugged
38	Battery Plus

Cobra Lever 8-way Connector

8-WAY	DESCRIPTION
1	Shift Control Input (Mode Auto)
2	Shift Control Input (Mode Common)
3	Shift Control Power Minus
4	Shift Control Power Plus
5	Dash Lights
6	Service Light Output
8	Shift Control Input (Mode Manual)
7	Shift Control Input (Mode Common 2)

Electric Clutch Actuator (ECA) 2-way Connector

2-WAY	DESCRIPTION
1	Battery Negative
2	Battery Positive (Fused)

Push Button Pinout Table

FROM	TO	DESCRIPTION
J1-27	C2-F2	HIL LOW (Proprietary CAN)
J1-28	C2-F1	HIL HIGH (Proprietary CAN)
J1-25	C2-J3	Shift Control Power Minus
J1-31	C2-C1	Shift Control Power Plus
	C2-B3	Dimmer Control Input

Torque Specifications

Description	Torque Value lbs. ft. [N•m]	Thread size	Additional Comments
Transmission-to-Engine capscrews	Refer to OEM for specifica- tion		
Clutch-to-Flywheel capscrews			
7/16 x 2.25 x 14	40-50 lb-ft [54-68 Nm]	7/16 x 2.25 x 14	H.D.
3/8 x 2.25 x 16	30-35 lb-ft [41-47 Nm]	3/8 x 2.25 x 16	M.D.
M10 x 1-3/8	26-35 lb-ft [35-47 Nm]	M10 x 1-3/8	
M10 x 1-3/4	26-35 lb-ft [35-47 Nm]	M10 x 1-3/4	
1 Reverse switch	20-25 lb-ft [27-34 Nm]	9/16"-18	
1 Neutral switch/cap	20-25 lb-ft [27-34 Nm]	3/4"-16	
2 Transmission ECU 38-Way Connectors Cap- screws	25 +/- 3 lb-in [2.82 +/- .33 Nm]	M5 x 0.8	
1 Push Button Shift Controller 30-Way Con- nector Capscrew	10 +/- 3 lb-in [1.1 +/- .33 Nm]		
2 Push Button Shift Controller Backing Plate nuts and lockwashers	14-16 lb-in [1.58-1.8 Nm]		
2 LCIB Mounting Studs	60 lb-ft [81 Nm]	5/8" - 11	
2 LCIB Mounting Nuts	140-150 lb-ft [190-203 Nm]	5/8" - 18	
4 ECA Capscrews	25-35 lb-ft [47-61 Nm]	3/8" - 16	
4 ECA Support Bracket Capscrews	25-35 lb-ft [47-61 Nm]	3/8" - 16	Apply Loctite 242 to threads.
4 Splitter Solenoid Capscrews	21-27 lb-in [2.4-3.1 Nm]	#10-24	
4 Range Solenoid Capscrews	21-27 lb-in [2.4-3.1 Nm]	#10-24	
1 Main Shaft Speed Sensor Capscrew	8-10 lb-ft [10.8-13.6 Nm]	1/4"-20	

Appendix

1 Input Shaft Speed Sensor Capscrew	8-10 lb-ft [10.8-13.6 Nm]	1/4"-20	
2 Rail Sensor Capscrews	21-27 lb-in [2.4-3.1 Nm]		
2 Gear Sensor Capscrews	21-27 lb-ft . [2.4-3.1 Nm]		
2 Air Filter Regulator Capscrews	8-12 lb-ft [10.8-16.02 Nm]	1/4"-20	Apply Loctite 242 to threads.
1 Lubricant fill plug	60-75 lb-ft [47 - 61 Nm]	1¼-NPT	
2 Lifting Bracket Capscrews	35-45 lb-ft [47-61 Nm]	3/8"-16	Apply Loctite 242 to threads.
2 Output Yoke Capscrews	70-85 lb-ft [95-115 Nm]		
4 Rear Bearing Cover Capscrews	35-45 lb-ft [47-61 Nm]	3/8"-16	Apply Loctite 242 to threads.
Transmission Nodal Mount Capscrews	Refer to OEM for Specification		Apply Loctite 242 to threads.
Transmission Rear Mount Nuts/Capscrews	Refer to OEM for Specification	5/8" - 11	
2 Hex Hd. Screw	8-12 lb-ft [11-16 Nm]	1/4-20 UNC x 1/2	Adhesive
1 Screw, Mach, Hex	8-12 lb-ft [11-16 Nm]	1/4-20x5/8	Adhesive
1 Screw, Mack, Hex	8-12 lb-ft [11-16 Nm]	1/4-20x1.12	Adhesive
1 Screw, Hex Flange Hd.	20- 23 lb-ft [27-31 Nm]	M8x1.25x12	Adhesive
4 Hex Hd. Capscrew with Conical Washer	34-45 lb-ft [48-61 Nm]	.375-16 UNC-2A x 1.00	Adhesive
Hex Hd. Capscrew with Conical Washer	25- 35 lb-ft [34-47 Nm]	.375-24 UNC-2A x 1.25	Adhesive
4 Hex Hd. Capscrew with Conical Washer	25-35 lb-ft [34-47 Nm]	.375-24 UNC-2A x 1.75	Adhesive
2 Hex Hd. Capscrew with Conical Washer	34-45 lb-ft [48-61 Nm]	.4375-14 UNC-2A x 1.25	Adhesive
2 Bolt Output Yoke	74-81 lb-ft [100-110 Nm]	M12x60	N/A
2 Clutch Housing Mounting Nuts	140-150 lb-ft [190-203 Nm]	5/8"-18	N/A

Appendix

Hose Assembly, Oil	57-63lb-ft [77-85 Nm]	7/8"-14	Sealant
Hose Assembly, Oil	57-63 lb-ft [77-85 Nm]	7/8"-14	Sealant
Jam Nut	10-15 lb-ft [13-20 Nm]	.75-16 UNF-1B	N/A
Elbow, 90 Degree Reducing	40-50 lb-ft [54-67 Nm]	.500-14 NPTF-1	Sealant
Elbow, Street	40-50 lb-ft [54-67 Nm]	.500-14 NPTF-1	Sealant
Connector	40-50 lb-ft [54-67 Nm]	.500-14 NPTF-1	Sealant
Elbow, Street 90 Degree	84-120 lb-ft [9.5-13.6 Nm]	1/8-27 NPTF-1	Sealant
Hose Assembly, Air	84 - 120 lb-ft [9.5-13.6 Nm]	1/8-27 NPTF-1	Sealant
Capscrews	21- 27 lb-ft [2.4-3.1 Nm]	10-24	Adhesive
2 Upper Mounting Studs (External)	Refer to OEM for Specification	.625-18 UNF-3A	
2 Upper Mounting Capscrews (Internal)	Refer to OEM for Specification	.625-11 UNC-3B	
Clutch release bearing grease hose	30-35 lb-ft (40.6-47.4 Nm)	5/8"-18	N/A
Shift Lever Mounting Screws	23-31 lb-in (2.6-3.5 Nm)	M6 x 1	N/A

Change Control Log

Last Revised Date	Description of Clarifications and Updates
July 2015	<ul style="list-style-type: none"> • (pg 1) Added paragraph on the use of the GEN 2 ECA Power Pack in this guide starting November 2015 • (pg 13 - 34) Updated transmission views with Gen 2 ECA graphics (All document instances) • (pg 25) Updated lube specification for PS-164 Rev 7 to PS-386: all instances • (pg 35) Changed "3-Way Metri-Pack" to "2-Way Deutsch". • (pg 35) Changed "8-Way Metri-Pack" to "8-Way Deutsch" • (pg 36) Changed "(Metri-Pack) - 3-Way 12124685" to "(Deutsch) - 2-Way DTM06-08SA-E003" • (pg 40) Update Connector Pin Out graphic and table to Deutsch configuration • (pg 40) Change fuse rating from "50" to "40" amp • (pg 40) Update ECA graphic • (pg 41) Updated Connector graphic Pin Out and table to Deutsch configuration • (pg 59) Added parameter "Transmission Mode 1 Indicator" SPN "2536" to ETC7 table • (pg 54) Added "Trans Fluids 2 (TRF2)" "PGN 64917" table." Source Address:3 (Transmission #1)" • (pg 61) Added new TC1 Table for Neutral Coast • (pg 70) Removed all bulleted parameter detail in OEM VEPS section. Replaced with "Refer to OEM VCP documentation for configurable VEPS parameters" • (pg 83) Replaced "50" with "40" in section 2 of chart for UCA power • (pg 88, 89 & 90) Updated graphic to eliminate 3rd connector which is not present in GEN 2 ECA Power Pack: All instances • (pg 95, 96, 97 & 99) Updated ECA graphic to GEN 2 ECA Power Pack • (pg 102) Changed "3-Way" to "2-Way" in ECA title and chart • (pg 102) Changed "A" "B" "C" to "1" "2" pin out to match Deutsch connector • Removed "ECA Engine Speed Sensor Jamb Nut" torque requirement in Torque Specification table.
December 2014	Added additional SSPTO Configurations
September 2014	<ol style="list-style-type: none"> 1. ECA Mounting torque changes <ul style="list-style-type: none"> - Pages: 21, 99 2. Changes to J1939 Start Enable Type requirements <ul style="list-style-type: none"> - Page 43 3. Rewrote Grade Sensor calibration procedure for ServiceRanger 4 <ul style="list-style-type: none"> - Page 78 4. Updated Diagnostic Procedure from TRTS0940 <ul style="list-style-type: none"> - Pages: 81, 82, 83

Change Control Log

Last Revised Date	Description of Clarifications and Updates
June 2014	<ol style="list-style-type: none"> 1. Added split dimension to the bottom of page 22 after ECA installation steps
March 2013	<ol style="list-style-type: none"> 1. Added UltraShift <i>PLUS</i> LSE, VHP, and VAS information 2. Updated Auxiliary Transmission information and image 3. Added updated notes to the Vehicle Space Claim section to reflect the new models (LSE, VHP, VAS) 4. Removed oil filter requirement 5. Added J1939 Start Enable Type option 6. J1939 Data Link Received Messages: Corrected CCVS, EBC1 and EEC1 tables
September 2012	<ol style="list-style-type: none"> 1. (pg 66) Added bullet to OEM Vehicle Equipment Programming Station (VEPS) section 2. (pg 67) Add Engine driven PTOs section 3. (pg 67) Renamed PTO Inputs section to Transmission mounted and Split Shaft PTO Inputs 4. (pg 68) Renamed PTO Configurations section to Transmission mounted and Split shaft PTO Configurations
June 2012	<ol style="list-style-type: none"> 1. (pg 8) Added note to Cab Floor Access Plate Requirements in Vehicle Space Claim section 2. (pg 26) Added Transmission Component Temperature Requirements to Cooler Requirements section

Change Control Log

Last Revised Date	Description of Clarifications and Updates
Jan 2010	<ol style="list-style-type: none"> 1. (pg 7) Added oil to water coolers required 2. (pg 7) added LAS units do not require rear support 3. (pg 8) Removed special clutch housing bolt torque pattern 4. (pg 13) Added PBSC mounting thread size 5. (pg 14) Added shift cobra lever mounting bolt size 6. (pg 20) Revised pilot bearing table 7. (pg 20) Revised grease hose torques 8. (pg 21) Added if transmission needs to be removed ECA must be removed first 9. (pg 22) Added replace tie straps that secure harnessing 10. (pg 23) Removed old instructions on installing engine speed sensor 11. (pg 23, 24) Removed engine speed sensor electrical specs 12. (pg 25) Added end yoke retaining bolt size 13. (pg 26) Removed LAS from rear support section 14. (pg 27) Added 80 psi requirement for LAS air regulator 15. (pg 31) Added oil to air not allowed 16. (pg 31) Reworded section 3. under cooling system specs 17. (pg 33) Added 12 volt only to operating conditions over temperature 18. (pg 34) Added Normally Closed to auto neutral switch requirements 19. (pg 41) Added part numbers for fuse holder 20. (pg 52) Revised stub lengths for data link 21. (pg 53) Removed line G from table 22. (pg 52) Added shield to table 23. (pg 54-64) Total rewrite of messaging section 24. (pg 65-66) Rearranged gear display section 25. (pg 67) Reworded hill start aid lamp requirements

Change Control Log

Change Control Log

Last Revised Date	Description of Clarifications and Updates
Jan 2010 (Continued)	<ol style="list-style-type: none"> 26. (pg 7) Added oil to water coolers required 27. (pg 7) added LAS units do not require rear support 28. (pg 8) Removed special clutch housing bolt torque pattern 29. (pg 13) Added PBSC mounting thread size 30. (pg 14) Added shift cobra lever mounting bolt size 31. (pg 67) Added Normally Closed to auto neutral section 32. (pg 69) Added Note under Service Lamp section 33. (pg 70) Added service kit number to PTO section 34. (pg 75) Removed initial clutch adjustment 35. (pg 76) Removed clutch adjustment section 36. (pg 77) Removed redundant line under process requirements 37. (pg 92) Added Wiring diagram - OEM Responsibility w/ Eaton Push Button 38. (pg 95) Added Wiring diagram - w/ Eaton Push Button 39. (pg 98) Corrected push button pinout table - dimmer control input 40. (pg 99) Added H.D. to comments in Torque specs 41. (pg 99) Added M.D. to comments in Torque specs 42. (pg 99) Changed comments for ECA engine speed sensor in Torque specs 43. (pg 99) Added thread size for transmission rear mount Capscrews 44. (pg 100) Added output yoke to torque specs table
March 2011	<ol style="list-style-type: none"> 1. Deleted Information from "About this manual" 2. Changed wording in "Product Familiarization" 3. Changed Graphics in "Vehicle Space Claim" 4. Changed Wording in "Clutch Interface" 5. Deleted "ECA Engine Speed Sensor Requirements" 6. Replaced Graphic in "Harness Routing Requirements" 7. Changed Graphic in "ECA Power Harness" 8. Changed P/N number and lb-ft rating on ECA Clutch installation section 9. Changed text under ECA Removal and Assembly Instruction in the ECA Clutch Installation section 10. Cooler Requirements section has been changed completely 11. Drawing updated for the Harness Routing Requirements 12. Updated information under Auto Neutral heading.

Copyright Eaton, 2015.

Eaton hereby grant their customers, vendors, or distributors permission to freely copy, reproduce and/or distribute this document in printed format. It may be copied only in its entirety without any changes or modifications. THIS INFORMATION IS NOT INTENDED FOR SALE OR RESALE, AND THIS NOTICE MUST REMAIN ON ALL COPIES.

Note: Features and specifications listed in this document are subject to change without notice and represent the maximum capabilities of the software and products with all options installed. Although every attempt has been made to ensure the accuracy of information contained within, Eaton makes no representation about the completeness, correctness or accuracy and assumes no responsibility for any errors or omissions. Features and functionality may vary depending on selected options.

For spec'ing or service assistance, call 1-800-826-HELP (4357) or visit www.eaton.com/roadranger. In Mexico, call 001-800-826-4357.

Roadranger: Eaton and trusted partners providing the best products and services in the industry, ensuring more time on the road.

Eaton

Vehicle Group
P.O. Box 4013
Kalamazoo, MI 49003 USA
800-826-HELP (4357)
www.eaton.com/roadranger

Printed in USA