

4 Set-up and Lubricate

Adjust Clutch Linkage

1 Adjust the clutch linkage until the yoke fingers contact the release bearing (zero free-play in the cab).

2 Fully press the pedal up to 5 times to move the release bearing slightly closer to the transmission and gain free-play in the cab.

3 Measure the distance between the release bearing and the clutch brake. The correct distance should be .500" – .560" (12.70 – 14.22 mm)

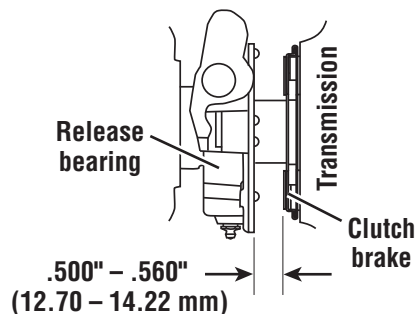
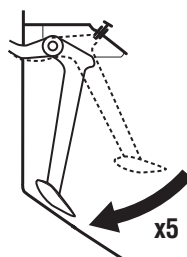
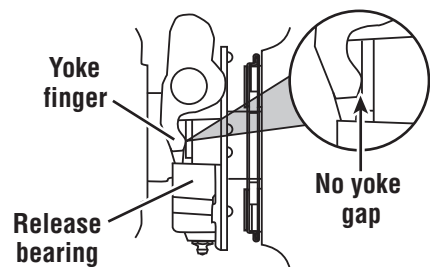

- If the distance is more than .560" (14.22 mm) return to **Step 1** and readjust the clutch linkage.

- If the distance is less than .500" (12.70 mm) consult Solo Service Manual (CLSM-0200).

Verify Clutch Brake Squeeze

4 Insert .010" (.25 mm) feeler gauge between the release bearing and the clutch brake. Press the pedal down to clamp the gauge.

- If the gauge does not clamp, return to **Step 1** and readjust the clutch linkage.

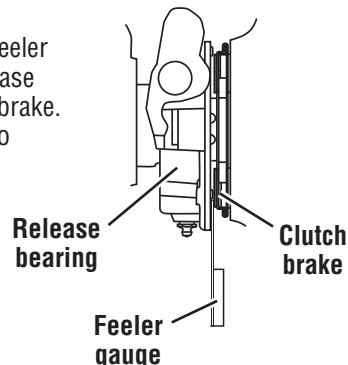

5 Slowly let up on the pedal and check the pedal position at the moment the gauge can be removed.

- If the pedal is less than 1/2" (12.7 mm) or more than 1" (25.4 mm) from the floor when the gauge can be removed, readjust the clutch linkage. (Repeat steps 4 and 5.)

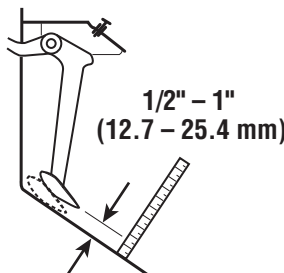

Verify Free-Play

6 Measure the free-play in the cab. The distance must be 1" (25.4 mm) or more.

- If the free-play distance is not 1" (25.4 mm) or more, go to **Step 7** and change the free-play.

IMPORTANT: DO NOT RESET THE CLUTCH. Do not change free-play by readjusting the clutch linkage.

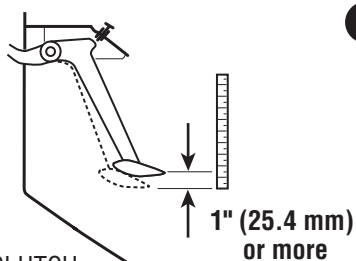

7 To change the free-play, adjust the upper pedal stop to raise or lower the pedal in the cab.

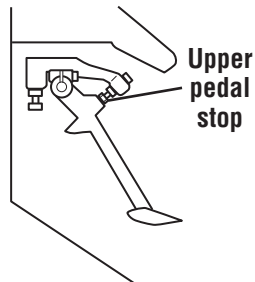

Lubricate

Use a lithium complex base grease with a minimum of 325° F (163° C) operating range meeting N.L.G.I. grade 1 or 2 specs.

Apply ample grease that visibly exits the opening and contacts the transmission shaft. This will lube the clutch brake when pedal is pressed.

NOTE: Refer to CLSM0200 for lube hose installation procedures used with hydraulic clutch release systems.

8 Apply grease to the input shaft and yoke

9 Apply grease to the cross shaft bushings and linkage pivot points.

10 Grease release bearing

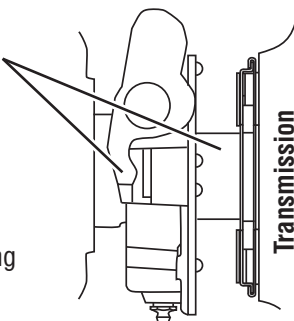

Install a Heavy-Duty 15.5" Self-Adjusting Clutch in 4 steps!

- 1 Measure**
- 2 Install Clutch to Flywheel**
- 3 Install Transmission**
- 4 Set-up and Lubricate**

Eaton Corporation
Clutch Division
201 Brandon Street
Auburn, IN 46706

Eaton® Heavy-Duty 15.5" Self-Adjusting Clutch

CLMT-1279
03/11 WP

Copyright Eaton Corporation, 2001.
All rights reserved.

EATON

Note: Refer to CLSM0200 for clutch removal procedures. Shipping bolts must be used to properly remove the clutch.

1 Measure

Measure Engine Flywheel Housing and Flywheel

Engine flywheel housing and flywheel must meet these specifications or there will be premature clutch wear. Remove old Pilot Bearing. All gauge contact surfaces must be clean and dry. Use a dial indicator and check the following:

Flywheel Face Runout

Secure dial indicator base to flywheel housing face. Put gauge finger in contact with flywheel face near the outer edge. Rotate flywheel one revolution. Maximum runout is .008" (.20 mm).

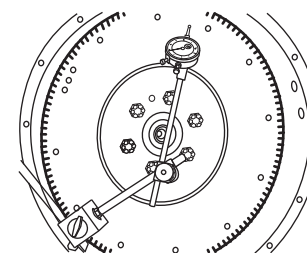

Flywheel Housing I.D. Runout

Secure dial indicator base to crankshaft. Put gauge finger against flywheel housing pilot I.D. Rotate flywheel one revolution. Maximum runout is .008" (.20 mm).

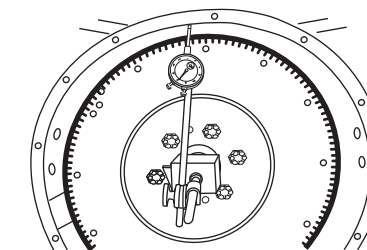

Pilot Bearing Bore Runout

Secure dial indicator base to flywheel housing face. Position gauge finger so that it contacts pilot bearing bore. Rotate flywheel one revolution. Maximum runout is .005" (.13 mm).

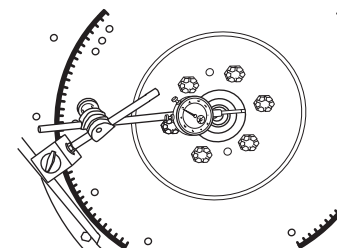

Flywheel Housing Face Runout

Secure dial indicator base to flywheel near the outer edge. Put gauge finger in contact with face of flywheel housing. Rotate flywheel one revolution. Maximum runout is .008" (.20 mm).

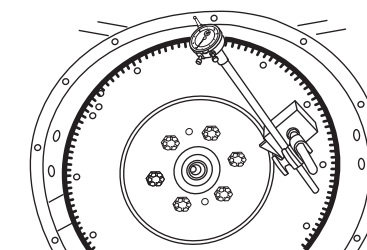

2 Install Clutch to Flywheel

IMPORTANT: Use the Eaton Clutch Selector Guide (CLSL-1511) to make sure you have the right clutch!

CAUTION: An assembled clutch weighs about 150 lbs. (68 kg). Avoid the risk of injury. Use proper equipment when lifting a clutch.

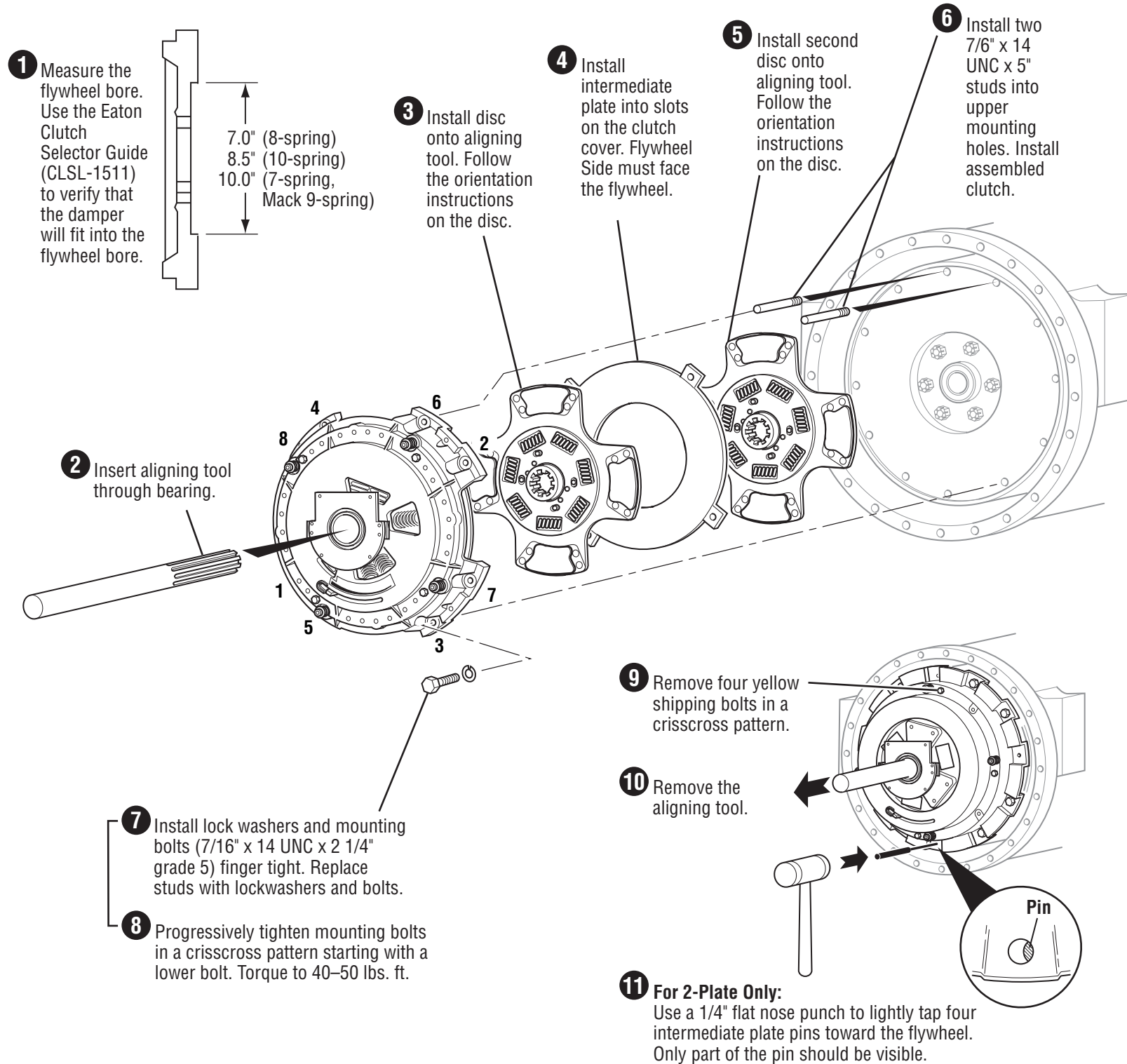

3 Install Transmission

Check Transmission For Wear

Replace any worn components.

Transmission Bearing Retainer Cap

A worn/rough bearing retainer cap may cause the clutch brake to wear prematurely.

Cross Shaft And Bushings

Excessive wear at these points can cause side loading on the sleeve bushing, bushing failures and yoke bridge contact with the clutch when the pedal is down.

Release Yoke

Worn fingers can cause bushing wear and yoke interference when the pedal is down.

Input Shaft Splines

Any wear on the splines will prevent the driven discs from sliding freely, causing poor clutch release (clutch drag). Slide discs full length of shaft to check for twisted shaft splines.

Input Shaft

Wear (roughness) can reduce sleeve bushing life and cause it to come out.

Clutch Brake

Replace if worn.

Measure Input Shaft

Length should be 8.657" (219.89 mm) nominal, and not greater than 8.71" (221.23 mm). Ref. 1990 SAE handbook 4:36.106. Replace transmission bearing retainer cap if length is greater than 8.71" (219.89 mm).

Fasten Transmission To Flywheel Housing

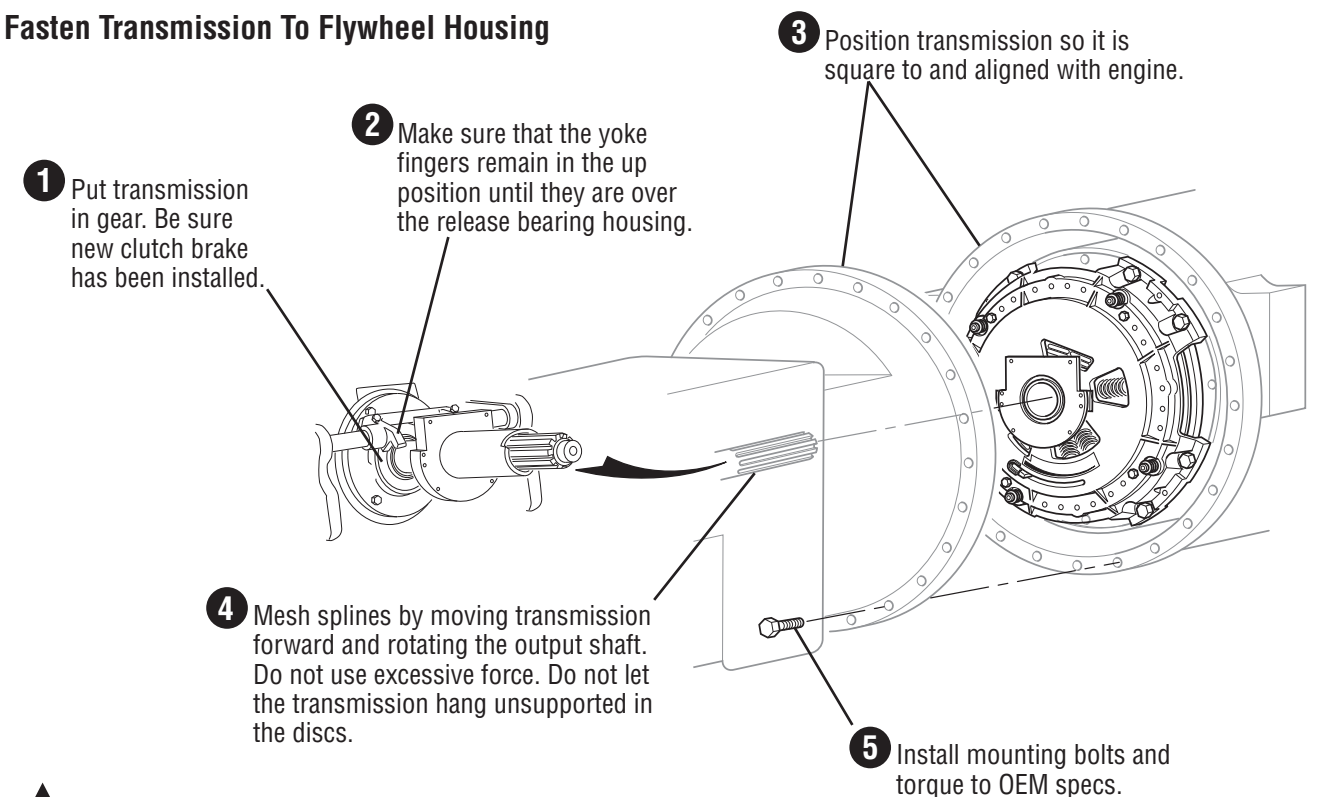

CAUTION: Do not pull on release arm to install transmission. This will cause the clutch to over adjust.